

D347 instruction manual

(Manufacturer shall have the right to change the contents of the manual without prior statement!)

D347's appearance(80mm Thermal kiosk printer):



D347 instruction manual

CATALOG

1. Summary	5
1.1 Product Features	5
1.1.1 General Specifications	5
1.1.2 Main Application and Ranges	6
1.1.3 Product Features	7
1.1.4 Supported character sets	8
1.1.5 Printer mechanism	8
1.1.6 Function and application	8
1.1.7 Hardware	9
1.2 The main purpose	9
1.3 Environmental Conditions	9
1.4 Electrical Characteristics	9
1.5 Status light	10
1.6 Product Safety	10
1.7 Matters need attention	11
2. Installion	12
2.1 D347 printing module operation instruction	12
2.2 D347 Paper roll installation	12
2.3 D347 presentation	14
2.4 D347 Power connection	17
3. Accessories	18
3.1 Power Supply Connector	18
3.2 USB connector cable	18
3.3 RS-232 connector cable	19
3.3.1 RS-232 Serial Interface	19
3.4 DIP Switch	21
4. Functions	22
4.1 List of Commands	22
4.1.1 Kanji command list	24
4.2 Commands	24
4.2.1 Command Notation	24
4.2.2 Explanation of Terms	25
4.3 Commands explanation	27
4.3.1 Control Commands	27
ESC @	27
GS (A pL pH n m	27
HT	27
LF	28
CR	28
ESC J n	28
ESC d n	29
ESC c 5 n	29

D347 instruction manual

4.3.2 Character parameter setting command	29
ESC ! n	29
GS ! n	30
ESC M n	31
ESC - n	32
ESC E n	32
ESC G n	33
GS B n	33
ESC V n	34
FS &(Kanji Control Commands)	34
FS .	35
FS ! n	35
FS - n	36
FS S n1 n2	37
ESC R n	37
ESC { n	38
GS c	38
4.3.3 Parameter setting command	39
ESC \$ nL nH	39
ESC \ nL n	39
ESC D n1 ... nk NULL	39
ESC 2	40
ESC 3 n	40
ESC SP n	41
ESC a n	41
GS L nL nH	41
GS :	42
4.3.4 Graphics / image print command	42
GS v 0 m xL xH yL yH d1 ... dk	42
FS P n m	44
GS * x y d1 ... d (x y 8)	45
4.3.5 Bar code print command	45
GS h n	45
GS w n	46
GS H n	46
GS f n	47
GS p n	47
GS k	47
4.3.6 Printer Status Feedback	51
DLE EOT n	51
DLE ENQ n	53
GS r n	54
4.3.7 Cutter Control	55
GS V m/GS V m n	55

D347 instruction manual

ESC i	55
ESC m	55
5. Storage.....	56
6. Appendix.....	56
Appendix A : Miscellaneous notes.....	56
A.1 Notes on Printing and Paper Feeding.....	56
A.2 Notes on Connecting the External Power Supply	57
Appendix B : CODE128 BAR CODE	57
B.1 Description of the CODE128 Bar Code	57
B.2 Code Tables	58
Appendix C : Switching Online and Offline.....	61

D347 Manual

1. Summary

This Manual is used for the D347 print module. If there are any questions, please contact us!

1.1 Product Features

1.1.1 General Specifications

	items	Specifications
Print	Printing method	80mm Thermal dot line printing
	Total dots per line (dot/lines)	576dots
	Printable dots per line (dot/lines)	576dots
	Simultaneously activated dots	96dots
	Print Density	85%
	Resolution	W 8 dots/mm*H 16 dots/mm
	Paper feed pitch	0.03125mm
	Maximum print speed (mm/s) max	170
	Print width (mm)	72
	Paper width (mm)	80mm
	Paper cutting method	Slide cutting
	Type of paper cutting	Full cut and Partial cut
Detection	Thermal head temperature detection	Thermistor
	Platen position detection	mechanical switch
	Out-of-paper detection	Reflection type photo interrupter
	Cutter home position detection	Transmissive type photo interrupter
Condition	Operating voltage range(Vp)	24V±10%
	Current consumption	Approximately 1.75A
	Autocutter current consumption	6.0 A max
Temperature	Operating temperature	-10—60° C (Non condensing)
	Storage temperature	-20—70° C (Non condensing)
	Operating humidity	10—85%RH (Non condensing)
Life span	Activation pulse resistance	100 million pulses or more
	Abrasion resistance(km)	50km or more
Appearance	Dimensions(include mounth part)	W207.3mm*D121.5mm*H127.2mm
	Mass	Approximately 550g

1.1.2 Main Application and Ranges

(1) Dimension diagram:

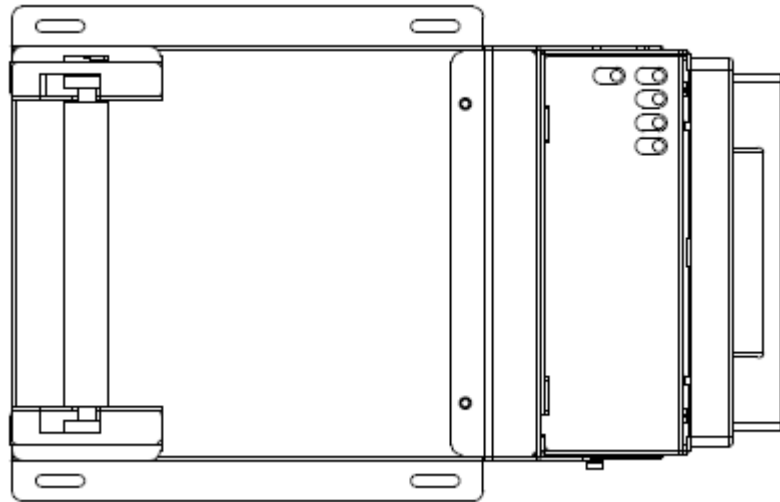
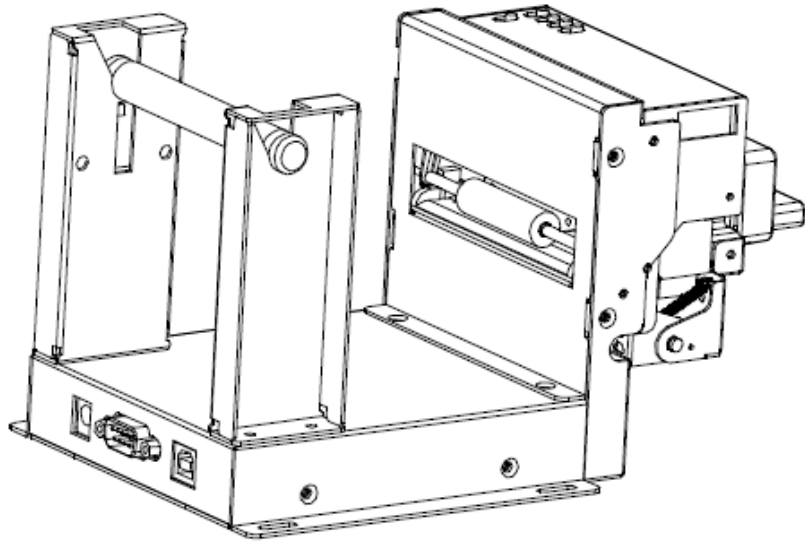

D347 instruction

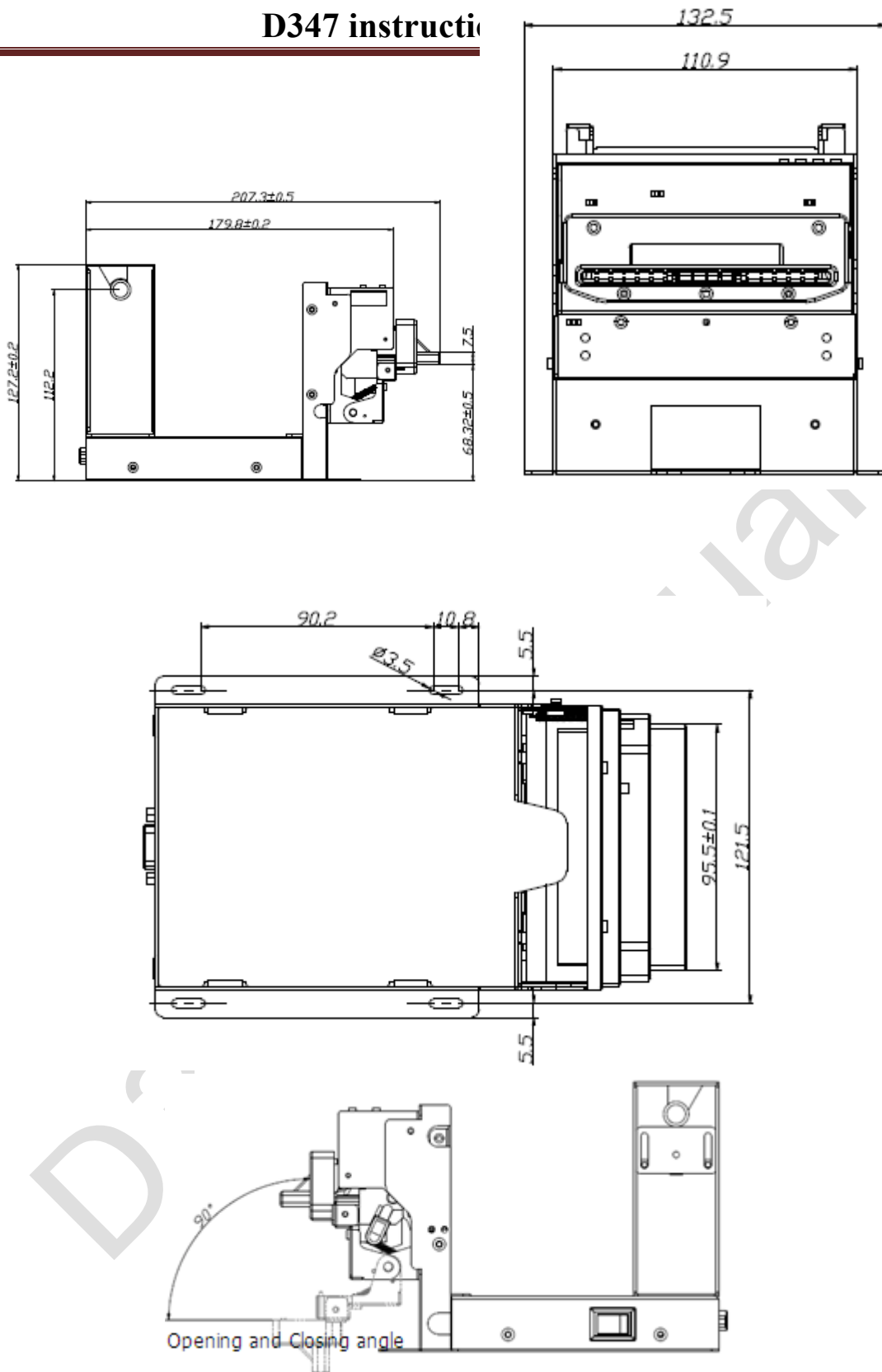

1.1.3 Product Features

D347 use Seiko printer machine CAPD347, combined with the company

D347 instruction manual

independent research and development D347 PCB and metal structure. Small panel structure, using the latest ARM design and printers movement in the same institution, reduce the space of the installation, the installation of improve product reliability; The design is exquisite, stable performance and fashion appearance. With automatic feed, automatic paper cutting, paper detection, paper near end sensor, paper prevent jam, paper pull, paper presenter and so on.

Interface: Serial port (RS-232 or TTL), USB, parallel.

Driver Support: XP /Win7/ WIN8 (32bit and 64bit) .

Barcode fuction: Support a dimensional barcode, such as CODE 93, CODE128 etc, support the two-dimensional barcode PDF417, QRCODE.

Paper pull and paper prevent jam:

Paper near end sensor: Onlight: noamal state, paper is enough.

Offlight: paper near end sensor.

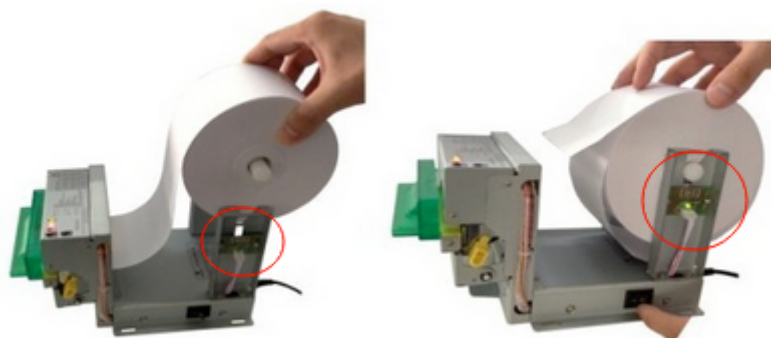

1.1.4 Supported character sets

- FONT A: 12*24 dot characters;
- FONT B: 9*17 dot characters;
- Kanji: Support GB18030 Simplified Chinese (24*24 dots)
Support GB2312 Simplified Chinese (16*16dots) (Please contact us)

1.1.5 Printer mechanism

Now it adopts Seiko printer mechanism.

1.1.6 Function and application

- Apply to ESC/POS standard command (customization command provided by company).
- Character size can be enlarged to 64 times.
- It can make reiteration and copy printing. It can print bar code (palisade barcode, standard EAN13 barcode).

D347 instruction manual

- It can choose the character size by command (12*24/9*17).
- It can choose the character size by command (24*24/16*16).
- It can print bitmap.
- It can choose printing pattern and page by software setup.

1.1.7 Hardware

- It equipped with Serial port (RS-232 or TTL) /USB.
- It equips with power adapter, paper near end sensor, control switch, paper presenter, communication cable, etc.
- It can add paper prevent jam paper pull and paper detection function.

1.2 The main purpose

D347 module is our new design printing module; it has high speed, low noise and good reliability. Moreover, it owns compact structure, which is convenient for installation.

The control board supports various barcode printing, including: EAN8, EAN13, CODE39, CODE128 one-dimension barcodes, and the PDF417 qr code printing, etc.

The best outstanding feature is our ALL-IN-ONE design concept control board and printer mechanism are in one structure, it commendably takes user' design into consideration, this can provide more convenience for users. It can apply to different industrial areas. For example: ATM、 The parking lot, self-service equipment, etc.

1.3 Environmental Conditions

◆ Temperature:

Operating: -10-60° C

Storage: -20-70° C

◆ Humidity:

Operating: 10-85% RH(non-condensation)(85%RH must be at 40° C)

1.4 Electrical Characteristics

- ◆ Supply voltage: 24V
- ◆ Current consumption(at 24V)
 - High speed mode:
 - Peak: Approximately 6.0A
 - Mean: Approximately 1.75A

1.5 Status light

There are three LED lights on the machine, use to indicate each state, meaning is as follows:

- ◆ Green LED: onlight, power supply;
- ◆ Red(two) LEDs: quick-flashing, power voltage is wrong.
- ◆ ERROR_LED is offlight, and the PE_LED flash slowly, it means the lack of paper, can be normal after the paper loading.
- ◆ After paper loading , red LED is offlight; if paper near end sensor is valid, when the paper is not enough, PE is bright but the printer can continue to print.

1.6 Product Safety

✧ Do not apply voltage or current to any pins in excess of the absolute maximum ratings.If voltage or current in excess of the absolute maximum ratings is applied, excess current will flow through the device, which may result in heat damage.

Absolute Maximum Ratings

Item	Symbol	Rated value	Unit
Input voltage	VIN	26.4	V
Storage temperature	Tstg	-20 to 70	° C

Recommended Operating Conditions

Item	Symbol	Standard value			Unit
		Min.	Typ.	Max.	
Supply voltage to the printer	Vp	21.6	24	26.7	V
Operating temperature	Topr	10	--	60	° C
Storage humidity	Hopr	10	--	85	%

✧ Do not short-circuit any of the output pins with the power supply.Short-circuiting an output pin with a low-impedance power supply may cause heat damage due to excess current or may melt the bonding wire.

✧ During transport or storage, protect the device by storing it in conductive sponge, aluminum foil, etc.

✧ Do not drop conductive material such as a paper clip onto the circuit board.Short circuiting pins on the board may cause heat damage due to excess current or may melt the bonding wire.

✧ Be sure to connect the devices with the specified cables.Improper connection may cause fire or shock.

✧ Never disassemble or modify this product.Tampering with this product may result in injury, fire, or electric shock.

✧ Be sure to set this equipment on a firm, stable, horizontal surface.Product

D347 instruction manual

may break or cause injury if it falls.

✧ Do not use in locations subject to high humidity or dust levels. Excessive humidity and dust may cause equipment damage, fire, or shock.

✧ Do not place heavy objects on top of this product. Never stand or lean on this product. Equipment may fall or collapse, causing breakage and possible injury.

✧ To ensure safety, please unplug this product prior to leaving it unused for an extended period.

1.7 Matters need attention

1. Recommend that client use the power adapter provides by our company. If want to use your own power adapter, shall meet the following requirements: output voltage: 24V, rated current: 2A~3A.
2. User should not touch printing control board without any static protection, because static can damage any electrical components on board and leads to no work of board.
3. User should use standard thermal paper, or it can influence our printer, moreover, it can damage thermal head gradually.
4. The width, inner diameter, outer diameter of paper scroll have meet standard requirements, or it can make paper sensor unable to work and paper jam.
5. User can't pull out the cable or power wire when the board is power on.
6. After long time working printer head will emit heat normally, but user can not touch it directly, or will get scald.
7. There is amounts of frictional force between the rubber roll and thermal head, so user can not press paper feeding button when where is no paper or it can damage thermal head.
8. User should clean thermal head regularly (use C_2H_5OH).
9. User should clean paper sensor regularly.

NOTE: User can not turn on and turn off power continuously, after 10 seconds can restart the printer.

2. Installion

2.1 D347 printing module operation instruction

For example:

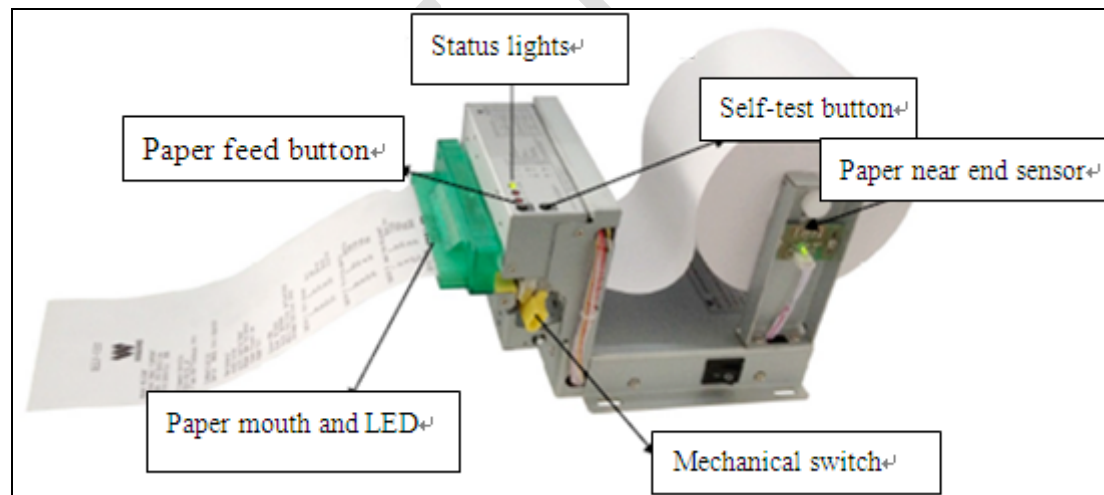
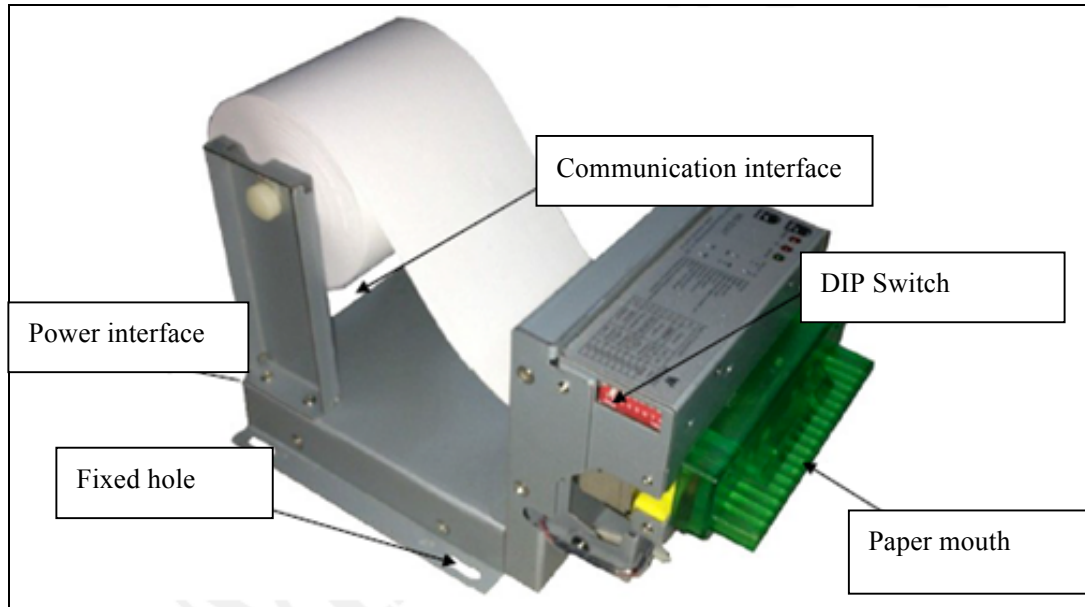

2.2 D347 Paper roll installation

- 1) Use scissors to snip paper in order to make it flat, as follows:

D347 instruction manual



- 2) put the paper roll horizontally or upright into the paper entry when printer is on power, make sure the thermal layer up, as follow:

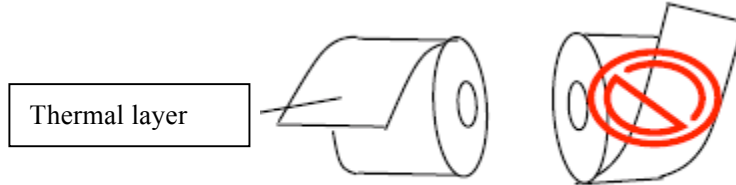

- 3) When the printer detects the paper, then the printer will feed paper automatically.

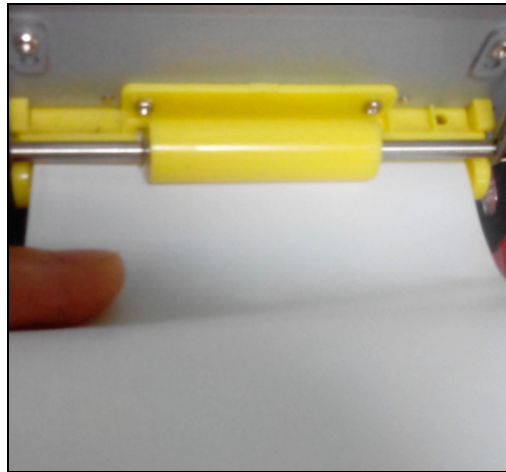

- 4) Press the Self-test button, then printer prints out a self- test page. As follow:

D347 instruction manual



- 5) According to the self-test page, set the DIP switch position, accomplish the corresponding function requirements.

2.3 D347 presentation

1. After power on, go for a paper and automatically cut. When install paper-presenter structure, the feeding length is not enough, cutter will not cut. After printing, if the paper has not been taken out, the paper will recycling in a few seconds.
2. Set the DIP switch is invalid or valid. When the paper near end sensor is valid, in the situation of paper enough, the status indicator PE_LED lights off; Paper is not enough, the status indicator PE_LED lights on, the indicator on the paper near end sensor module will light off.

D347 instruction manual

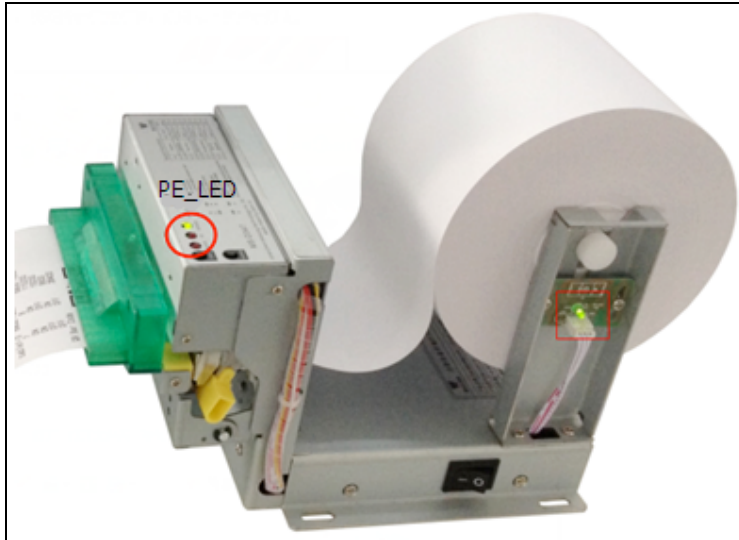

(paper is enough)

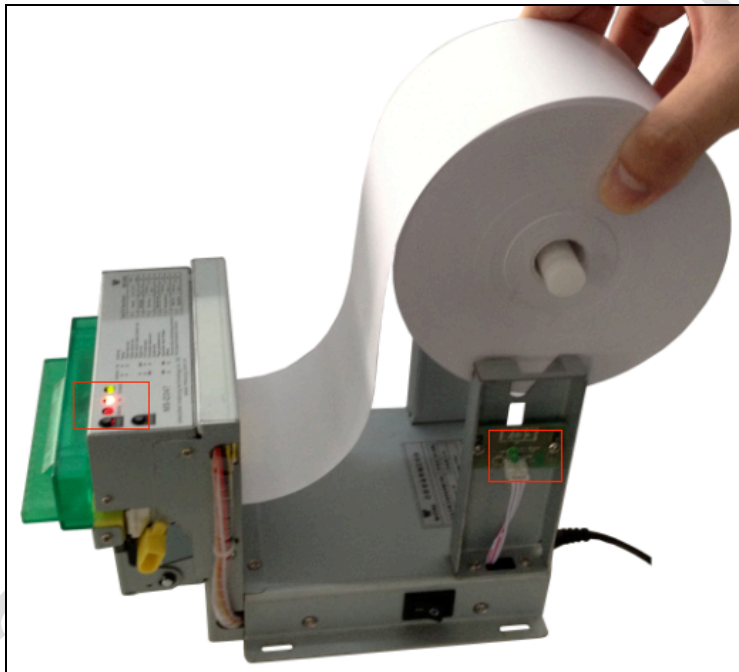

(paper is not enough)

3. With the hand to push out of the paper, cutter automatically cut off the printing paper, LED lights on, after cut off, LED lights off, and goes on feeding paper, then continue to print.

D347 instruction manual



4. With the hand to block out of the paper, paper printers automatically stop, LED lights on, the paper feed smoothly, LED lights off, and then continue to print.



5. If paper jam occurs, tear the paper outside the paper entry, and pull yellow wrench, open the print head and pull out the jammed paper towards the paper feeding. And then return cover, back to power on, according to the installation of the paper for printer paper again.
6. Press “Feed” button; observe whether the fault is excluded.



(Tear the paper outside the paper entry)

D347 instruction manual



(Pull yellow wrench, open the print head)

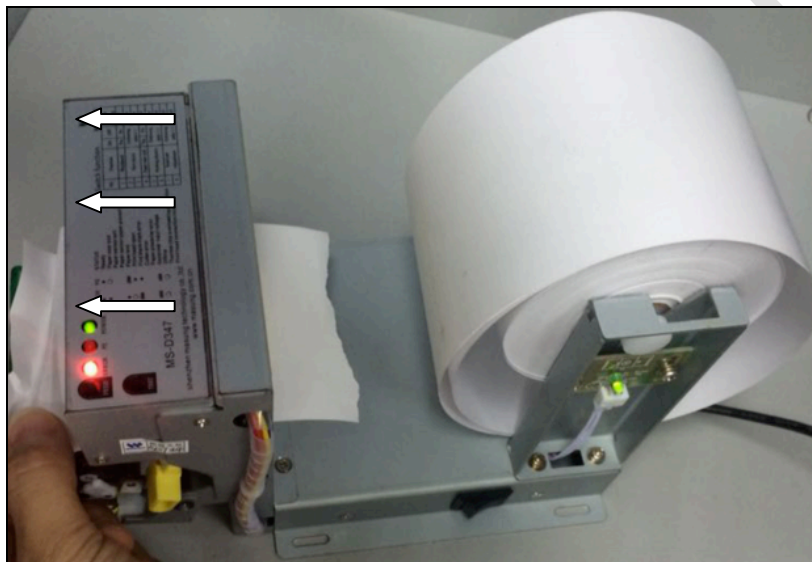

(pull out the paper towards the paper feeding)

LED lights flash, if you have special requirements, can communicate with our company.

2.4 D347 Power connection

- ① Firstly user should check whether adapter is connected with printer or not.
- ② Secondly user should check whether input voltage is $24 \pm 10\%V$ or not.
- ③ If the input current and voltage of adapter meet requirements, user can connect the power cable with adapter.
- ④ After power on user should check whether printer does work, if the indicators work (POWER_LED on, PE_LED flashing slowly, ERROR_LED off), if abnormality user should switch off the power quickly.

Notice: Before any cable connects to printer, user should make sure the power

off.

3. Accessories

The interface of D347:

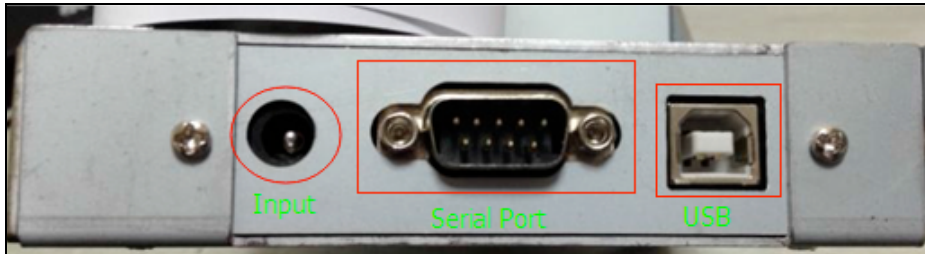

3.1 Power Supply Connector

<Power supply connection cable> – female interface, 2.5mm, as follow



3.2 USB connector cable

<Type B connector cable>, as follow



3.3 RS-232 connector cable

RS-232 connector cable- female interface, as follow



3.3.1 RS-232 Serial Interface

- 1) Data transmission: Serial
- 2) Synchronization: Asynchronous
- 3) Baud rate: 115200, 9600, 19200, 38400bps(bit per second)
- 4) Data word length: 8 bits (fixed)
- 5) Parity Setting: None,even,odd
- 6) Stop bits: 1 or more
- 7) Connector(printer side): male D-SUB9 pin connector
- 8) Signal levels: MARK = -3 to -15 V: Logic "1"/ OFF
SPACE = +3 to +15 V: Logic "0"/ ON
- 9) Handshaking: Software: Xon/Xoff
Hardware: RTS/CTS或DTR/DSR
- 10) Signal Assignments and Functions:

D347 instruction manual

Pin number	Signal name	Signal direction	Function
1	NC	NC	No connection
2	RXD	Input	Receive data
3	TXD	Output	Transmit data
4	DTR	Output	<p>1) When DTR/DSR control is selected, this signal indicates whether the printer is busy. SPACE indicates that the printer is ready to receive data, and MARK indicates that the printer is busy.</p> <p>2) When XON/XOFF control is selected, The signal indicates whether the printer is correctly connected and is ready to receive data. SPACE indicates that the printer is ready to receive data. The signal is always SPACE except in the following cases: During the period from when the power is turned on to when the printer is ready to receive data: During the self-test.</p>
5	SG	--	Signal ground
6	DSR	Input	<p>This signal indicates whether the host computer can receive data. SPACE indicates that the host computer can receive data, and MARK indicates that the host computer cannot receive data.</p> <p>1) When DTR/DSR control is selected, the printer transmits data after confirming this signal (except when transmitting data by DLE EOT, and GS a).</p> <p>2) When XON/XOFF control is selected, the printer does not check this signal.</p>
7	RTS	Output	Same as DTR signal
8	CTS	Input	<p>This signal indicates whether the host computer can receive data. SPACE indicates that the host computer can receive data, and MARK indicates that the host computer cannot receive data.</p> <p>1) When DTR/DSR control is selected, the printer transmits data after confirming this signal (except when transmitting data by DLE EOT, and GS a).</p> <p>2) When XON/XOFF control is selected, the printer does not check this signal.</p>
9	NC	NC	No connection

11) Serial interface connection example:

D347 instruction manual

Board			User side	
D-sub9 Pin No.	Signal Name		Signal Name	D-SUB9 Pin No.
1	(NC)		DCD	1
2	RxD	←	RxD	2
3	TxD	→	TxD	3
4	DTR	←	DTR	4
5	SG	→	SG	5
6	DSR	←	DSR	6
7	RTS	→	RTS	7
8	CTS	←	CTS	8
9	(NC)		RI	9

3.4 DIP Switch



SW No.	Function	ON	OFF	Factory setting
1	BM sensor	Enabled	Disable	Off
2	Interface selection	Refer to table 3.4.1		Off
3				Off
4	Paper near-end sensor	Enabled	Disable	Off
5	Print density selection	Refer to table 3.4.2		Off(*)
6				Off(*)
7	Baud rate Adjustment	Refer to table 3.4.3		Off(*)
8				Off(*)

(*)Effective only when the serial interface is selected.

Table 3.4.1 Interface choose

Interface	Switch number	
	2	3
Parallel interface	OFF	OFF
Serial interface	OFF	ON
	ON	OFF
USB	ON	ON

Table 3.4.2 Print Density Selection

Level	Print density	Switch number	
		5	6
1	145%	ON	ON
2	130%	OFF	ON
3	115%	ON	OFF
4	100%	OFF	OFF

Table 3.4.3 Baud Rate Selection

Transmission Speed (BPS)	Switch number
--------------------------	---------------

D347 instruction manual

	7	8
115200	ON	ON
9600	OFF	ON
19200	ON	OFF
38400	OFF	OFF

BPS: bit per second

Notice: DIP switches should not be changed while the printer power is on. Effective only when reset the printer.

4. Functions

4.1 List of Commands

Command	Name	Command classification		Standard mode
		Executing	Setting	
HT	Horizontal tab	0		0
LF	Print and line feed	0		0
CR	Print and carriage return	0		0
DLE EOT	Real-time status transmission	0		0
DLE ENQ	Real-time request to printer	0		0
ESC SP	Set right-side character spacing		0	0
ESC !	Select print mode(s)		0	0
ESC \$	Set absolute print position	0		0
ESC *	Select bit-image mode	0		0
ESC -	Turn underline mode on/off		0	0
ESC 2	Select default line spacing		0	0
ESC 3	Set line spacing		0	0
ESC @	Initialize printer	0	0	0
ESC D	Set horizontal tab positions		0	0
ESC E	Turn emphasized mode on/off		0	0
ESC G	Turn double-strike mode on/off		0	0
ESC J	Print and feed paper	0		0
ESC M	Select character font			0
ESC R	Select an international character set		0	0
ESC V	Turn 90° clockwise rotation mode on/off		0	0
ESC \	Set relative print position	0		0
ESC a	Select justification		0	(0)
ESC c 3	Select paper sensor(s) to output paper-end signals		0	0

D347 instruction manual

ESC c 4	Select paper sensor(s) to stop printing		0	0
ESC c 5	Enable/disable panel buttons		0	0
ESC d	Print and feed <i>n</i> lines	0		0
ESC t	Select character code table		0	0
ESC{	Turn upside-down printing mode on/off		0	(0)
FS p	Print NV bit image	0		0
FS q	Define NV bit image		0	(0)
GS !	Select character size		0	0
GS*	Define downloaded bit image		0	0
GS (A	Execute test print	0		0
GS (E	User setup commands	0	0	(0)
GS (F	Set adjustment value(s)		0	0
GS (K	Select print control method(s)		0	0
GS (M	Customize printer control value(s)	0		(0)
GS /	Print downloaded bit image	0		●
GS :	Start/end macro definition	0	0	0
GS B	Turn white/black reverse printing mode on/off		0	0
GS C 0	Select counter print mode		0	0
GS C 1	Select count mode (A)		0	0
GS C 2	Set counter		0	0
GS C	Select count mode (B)		0	0
GS E	Select head control method		0	0
GS H	Select printing position of HRI characters		0	0
GS I	Transmit printer ID	0		0
GS L	Set left margin		0	(0)
GS T	Set print position to the beginning of print line	0		0
GS V	Select cut mode and cut paper	0		(0)
GS W	Set printing area width		0	(0)
GS ^	Execute macro	0		0
GS a	Enable/disable Automatic Status Back (ASB)	0	0	0
GS b	Turn smoothing mode on/off		0	0
GS f	Select font for HRI characters		0	0
GS h	Set bar code height		0	0
GS k	Print bar code	0		●
GS r	Transmit status	0		0
GS v 0	Print raster bit image	0		●
GS w	Set bar code width		0	0

4.1.1 Kanji command list

Command	Name	Command classification		Standard mode
		Executing	Setting	
FS !	Set print mode(s) for Kanji characters		o	o
FS &	Select Kanji character mode		o	o
FS -	Turn underline mode on/off for Kanji characters		o	o
FS .	Cancel Kanji character mode		o	o
FS C	Select Kanji character code system		o	o
FS S	Set left- and right-side Kanji character spacing		o	o
FS W n	Turn quadruple-size mode on/off for Kanji characters		o	o

[instructions]: Command classification

Executing: The printer executes the command, which does not then affect the following data.

Setting: The printer uses flags to make settings, and those settings affect the following data.

Standard mode:

o: Enabled.

(o): Enable only when the command is set at the beginning of a line.

●: Enable only when data is not present in the printer buffer.

4.2 Commands

4.2.1 Command Notation

[Name]	The name of the command;
[Format]	The code sequence; []k indicates the contents of [] should be repeated k times.
[Range]	Gives the allowable ranges for the arguments;
[Description]	Describes the function of the command;
[Details]	Describes the usage of the command in detail;
[Notes]	Provides important information on setting and using the printer command, if necessary;
[Default]	Gives the default values, if any, for the command parameters;
[Reference]	Lists related commands.

D347 instruction manual

The numbers denoted by $\langle \rangle$ H are hexadecimal.

The numbers denoted by $\langle \rangle$ B are binary.

The parameters in the range of data in the command format, based on the scope of the $\langle \rangle$ D, namely the Decimal number range. For example, $0 \leq n \leq 255$ ($\langle n \rangle$ D) .

4.2.2 Explanation of Terms

1) Receive buffer

The receive buffer is a buffer that stores, as is, the data received from the host (the reception data). The receive data is stored in the receive buffer temporarily, and is then processed sequentially.

2) Print buffer

The print buffer is a buffer that stores the image data to be printed.

3) Print buffer full

This is the state where there is no more room in the print buffer. If new print data is input while the print buffer is full, the data in the print buffer is printed out and a line feed is executed. This is the same operation as the LF(Print and line feed) operation.

4) Start of line

The start of line state satisfies the following conditions:

There is no print data (including spaces and portions of data skipped due to HT(Horizontal tab) currently in the print buffer.

The print position is not specified by the ESC \$(Set absolute print position) or ESC \ (Set relative print position) command.

5) Printable area

The maximum range within printing is possible under the printer specifications. The printable area for this printer is as follows:

For 80mm paper width model: approximately 72mm.

Dot pitch:

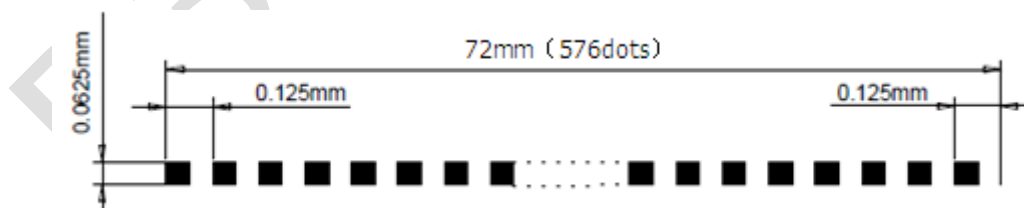

6) Printing area

Printing range is set by the command. The printing area area must be \leq the printable area.

D347 instruction manual

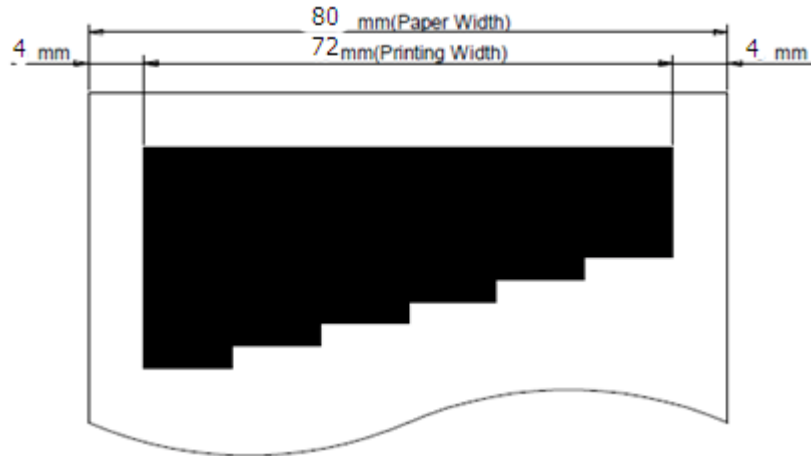

7) Ignore

The state in which all codes, including parameters, are read in and discarded, and nothing happens.

8) Inch

A unit of length. One inch is 25.4mm.

9) MSB

Most Significant Bit

10) LSB

Least Significant Bit

11) Baseline

The standard position for character data stored in the print buffer. The illustration below shows normal character positions in standard mode:

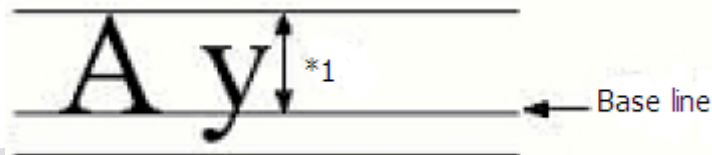

*1. When Font A (12×24 dots) is selected, this height is 21 dots.

When Font B (9×17 dots) is selected, this height is 16 dots.

Rotated characters in standard mode (only when Font A is selected):

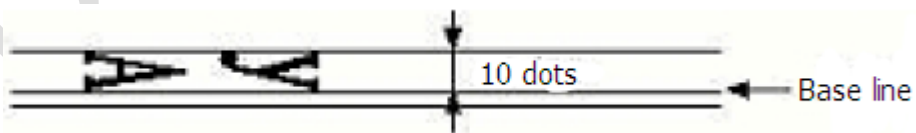

4.3 Commands explanation

4.3.1 Control Commands

ESC @

[Name] Initialize printer

[Format] ASCII ESC @
Hex 1B 40
Decimal 27 64

[Description] Clears the data in the print buffer and resets the printer mode to the mode that was in effect when the power was turned on.

[Notes] The data in the receive buffer is not cleared.

GS (A pL pH n m

[Name] Execute test print

[Format] ASCII GS (A pL pH n m
Hex 1D 28 41 02 00 00 02
Decimal 29 40 65 3 0 0 2

[Description] Executes a test print with a specified test pattern on a specified paper.

[Details]

- This command has enabled only when processed at the beginning of a line in standard mode.
- When this command is received during macro definition, the printer ends macro definition and begins performing this command.
- After the test print is finished, the printer resets itself automatically. Therefore, data already defined before this command is executed, such as user-defined characters, downloaded bit image, and macro, becomes undefined; the receive buffer and print buffer are cleared; and each setting returns to the default value.
- The printer also re-reads the DIP switch settings.
- The printer cuts the paper at the end of the test print.
- The printer goes BUSY while this command is executed.

HT

[Name] Horizontal tab

[Format] ASCII HT
Hex 09
Decimal 9

[Description] Moves the print position to the next horizontal tab position.

[Notes] •This command is ignored unless the next horizontal tab position has

D347 instruction manual

been set.

- If the next horizontal tab position exceeds the printing area, the printer sets the printing position to [printing area width + 1].
- Horizontal tab positions are set with ESC D(Set horizontal tab positions).
- If this command is received when the printing position is at [printing area width +1], the printer executes print buffer-full printing of the current line and horizontal tab processing from the beginning of the next line.

[Reference] ESC D(Set horizontal tab positions)

LF

[Name] Print and line feed

[Format] ASCII LF
Hex 0A
Decimal 10

[Description] Prints the data in the print buffer and feeds one line, based on the current line spacing.

[Note] This command sets the print position to the beginning of the line.

[Reference] ESC 2(default line spacing), ESC 3(set line spacing)

CR

[Name] Print and carriage return

[Format] ASCII CR
Hex 0D
Decimal 13

[Description] When automatic line feed is enabled, this command functions the same as LF;

when automatic line feed is disabled, this command is ignored.

[Reference] LF(Print and line feed)

ESC J n

[Name] Print and feed paper.

[format] ASCII ESC J n
Hex 1B 4A n
Decimal 27 74 n

[Range] $0 \leq n \leq 255$

[Description] Prints the data in the print buffer and feeds the paper [$n \times 0.125$ mm].

[Notes] •After printing is completed, this command sets the print starting position to the beginning of the line.

D347 instruction manual

- The paper feed amount set by this command does not affect the values set by ESC 2(default line spacing), ESC 3(set line spacing).

ESC d n

[Name] Print and feed n lines

[Format] ASCII ESC d n
Hex 1B 64 n
Decimal 27 100 n

[Range] $0 \leq n \leq 255$

[Description] Prints the data in the print buffer and feeds n lines.

- [notes]
- This command sets the print starting position to the beginning of the line.
 - This command does not affect the line spacing set by ESC 2 or ESC 3.
 - The maximum paper feed amount is 1016 mm {40"}. If the paper feed amount ($n \times$ line spacing) of more than 1016 mm {40"} is specified, the printer feeds the paper only 1016 mm {40"}.

[Reference] ESC 2(default line spacing), ESC 3(set line spacing)

ESC c 5 n

[Name] Enable/disable panel buttons

[Format] ASCII ESC c 5 n
Hex 1B 63 35 n
Decimal 27 99 53 n

[Range] $0 \leq n \leq 255$

[Description] Enables or disables the panel buttons.

When the LSB of n is 0, the panel buttons are enabled.

When the LSB of n is 1, the panel buttons are disabled.

- [Notes]
- Only the lowest bit of n is valid.
 - When the panel buttons are disabled, none of them are usable when the printer cover is closed.
 - In this printer, the only panel buttons is the FEED button.
 - When in macro execution standby, the FEED button is enabled regardless of the setting of this command. However, the paper cannot be fed.

[Default] n=0

4.3.2 Character parameter setting command

ESC ! n

[Name] Select print mode(s)

D347 instruction manual

[Format] ASCII ESC ! n
 Hex 1B 21 n
 Decimal 27 33 n

[Range] $0 \leq n \leq 255$

[Description] Selects print mode(s) using n as follows:

bit	Off/On	Hex	Decimal	Function
0	Off	00	0	Character Font A (12 × 24).
	On	01	1	Character Font B (9 × 17).
1	-	-	-	Undefined.
2	-	-	-	Undefined.
3	Off	00	0	Emphasized mode not selected.
	On	08	8	Emphasized mode selected.
4	Off	00	0	Double-height mode not selected.
	On	10	16	Double-height mode selected.
5	Off	00	0	Double-width mode not selected.
	On	20	32	Double-width mode selected.
6	-	-	-	Undefined.
7	Off	00	0	Underline mode not selected.
	On	80	128	Underline mode selected.

- [Details]
- When both double-height and double-width modes are selected, quadruple-size characters are printed.
 - The printer can underline all characters, but cannot underline the space set by HT or 90° clockwise rotated characters.
 - The thickness of the underline is that selected by ESC –, regardless of the character size.
 - When some characters in a line are double or more height, all the characters in the line are aligned at the baseline.
 - ESC M(Select character font)can also select character font type. However, the setting of the last received command is effective.
 - ESC E(Turn emphasized mode on/off)can also turn on or off emphasized mode. However, the setting of the last received command is effective.
 - ESC - (Turn underline mode on/off)can also turn on or off underline mode. However, the setting of the last received command is effective.
 - GS !(Select character size)can also select character size. However, the setting of the last received command is effective.
 - Emphasized mode is effective for alphanumeric and Kanji. All print modes except emphasized mode are effective only for alphanumeric.

GS ! n

[Name] Select character size

D347 instruction manual

[Format] ASCII GS ! n
 Hex 1D 21 n
 Decimal 29 33 n

[Range] $0 \leq n \leq 255$

($1 \leq$ vertical number of times ≤ 8 , $1 \leq$ horizontal number of times ≤ 8)

[Description] Selects the character height using bits 0 to 2 and selects the character width using bits 4 to 7, as follows:

Table 1

Character Width Selection

Hex	Decimal	Width
00	0	1(normal)
10	16	2(double-width)
20	32	3
30	48	4
40	64	5
50	80	6
60	96	7
70	112	8

Table 2

Character Height Selection

Hex	Decimal	Height
00	0	1(normal)
01	1	2(double-height)
02	2	3
03	3	4
04	4	5
05	5	6
06	6	7
07	7	8

- [Notes]
- This command is effective for all characters (alphanumeric and Kanji), except for HRI characters.
 - If n is outside the defined range, this command is ignored.
 - In standard mode, the vertical direction is the paper feed direction, and the horizontal direction is perpendicular to the paper feed direction. However, when character orientation changes in 90° clockwise-rotation mode, the relationship between vertical and horizontal directions is reversed.
 - In page mode, vertical and horizontal directions are based on the character orientation.
 - When characters are enlarged with different sizes on one line, all the characters on the line are aligned at the baseline.
 - The ESC ! (Select print modes) command can also turn double-width and double-height modes on or off. However, the setting of the last received command is effective.

[Default] n=0

[Reference] ESC !(Select print modes)

ESC M n

[Name] Select character font

[Format] ASCII ESC M n
 Hex 1B 4D n
 Decimal 27 77 n

[Range] n=0,1,16,17

[Description] Select the character font.

D347 instruction manual

n (Decimal)	Function
0	Character Font A(12*24) selected.
1	Character Font B(9*17) selected.
16	Kanji Character Font A (24*24) selected.
17	Kanji Character Font B(16*16) selected.

[Details] ESC ! (Select print modes) can also select character font types. However the setting of the last received command is effective.

[Reference] ESC ! (Select print modes)

ESC - n

[Name] Turn underline mode on/off

[Format] ASCII ESC - n
 Hex 1B 2D n
 Decimal 27 45 n

[Range] $0 \leq n \leq 2$

[Description] Turns underline mode on or off, based on the following values of n:

n	Function
0	Turns off underline mode
1	Turns on underline mode(1 dot thick)
2	Turns on underline mode(2 dots thick)

- [Notes]
- The printer can underline all characters (including right-side character spacing), but cannot underline the space set by HT(Horizontal tab).
 - The printer cannot underline 90° clockwise rotated characters and white/black inverted characters.
 - When underline mode is turned off by setting the value of n to 0 or 48, the following data is not underlined, and the underline thickness set before the mode is turned off does not change.
 - Changing the character size does not affect the current underline thickness.
 - Underline mode can also be turned on or off by using ESC !(Select print modes). Note, however, that the last received command is effective.

[Default] n=0

[Reference] ESC !(Select print modes)

ESC E n

[Name] Turn emphasized mode on/off

[Format] ASCII ESC E n
 Hex 1B 45 n
 Decimal 27 69 n

D347 instruction manual

[Range]	$0 \leq n \leq 255$
[Description]	Turns emphasized mode on or off When the LSB of n is 0, emphasized mode is turned off. When the LSB of n is 1, emphasized mode is turned on.
[Notes]	<ul style="list-style-type: none">• Only the least significant bit of n is enabled.• This command and ESC !(Select print modes) turn on and off emphasized mode in the same way. Be careful when this command is used with ESC !.
[Default]	n=0
[Reference]	ESC !(Select print modes)

ESC G n

[Name]	Turn on/off double-strike mode
[Format]	ASCII ESC G n Hex 1B 47 n Decimal 27 71 n
[Range]	$0 \leq n \leq 255$
[Description]	Turn double-strike mode on or off. <ul style="list-style-type: none">• When the LSB of n is 0, double-strike mode is turned off.• When the LSB of n is 1, double-strike mode is turned on.
[Notes]	<ul style="list-style-type: none">• Only the lowest bit of n is enabled.• Printer output is the same in double-strike mode and in emphasized mode.
[Default]	n=0
[Reference]	ESC E(Turn emphasized mode on/off)

GS B n

[Name]	Turn white/black reverse printing mode
[Format]	ASCII GS B n Hex 1D 42 n Decimal 29 66 n
[Range]	$0 \leq n \leq 255$
[Description]	Turn on or off white/black reverse printing mode. <ul style="list-style-type: none">• When the LSB of n is 0, white/black reverse mode is turned off.• When the LSB of n is 1, white/black reverse mode is turned on.
[Notes]	<ul style="list-style-type: none">• Only the lowest bit of n is valid.• This command is available for built-in characters and user-defined characters.• When white/black reverse printing mode is on, it also applies to character spacing set by ESC SP(Set right-side character spacing).• This command does not affect bit images, user-defined bit images, bar codes, HRI characters, and spacing skipped by HT(Horizontal tab),

D347 instruction manual

ESC \$(Set absolute print position), and ESC \ (Set relative print position).

- This command does not affect the space between lines.
- White/black reverse mode has a higher priority than underline mode. Even if underline mode is on, it is disabled (but not canceled) when white/black reverse mode is selected.

[Default] n=0

ESC V n

[Name] Turn 90° clockwise rotation mode on/off

[Format] ASCII ESC V n
Hex 1B 56 n
Decimal 27 86 n

[Range] $0 \leq n \leq 1$, $48 \leq n \leq 49$

[Description] Turns 90° clockwise rotation mode on/off
n is used as follows:

n	Function
0,48	Turns off 90° clockwise rotation mode
1,49	Turns on 90° clockwise rotation mode

- [Notes]
- This command affects printing in standard mode. However, the setting is always effective.
 - When underline mode is turned on, the printer does not underline 90° clockwise-rotated characters.
 - Double-width and double-height commands in 90° rotation mode enlarge characters in the opposite directions from double-height and double-width commands in normal mode.
 - If this command is input in page mode, the printer performs only internal flag operations.

[Default] n=0

[Reference] ESC !(Select print modes), ESC -(Turn underline mode on/off)

FS &(Kanji Control Commands)

[Name] Select Kanji character mode

[Format] ASCII FS &
Hex 1C 26
Decimal 28 38

[Description] Select Kanji character mode.

[Details] For Japanese model:

- This command is effective only when the JIS code system is selected.
- When the Kanji character mode is selected, the printer processes all Kanji code as two bytes each.

D347 instruction manual

- Kanji codes are processed in the order of the first byte and second byte.
- Kanji character mode is not selected when the power is turned on.
- Using FS C, the Kanji character code system is selected.

For Simplified Chinese/Traditional Chinese / Korean model:

- When The kanji character mode is selected, the printer checks whether the code is for Kanji or not; then processes the first byte and the second byte if the code is for Kanji.
- Kanji codes are processed in the order of the first byte and second byte.
- Kanji character mode is selected when the power is turned on.

[Reference] FS.(Cancel Kanji character mode), FS C(Select Kanji character code system)

FS .

[Name] Cancel Kanji character mode

[Format] ASCII FS .
Hex 1C 2E
Decimal 28 46

[Description] Cancel Kanji character mode.

[Details] For Japanese model:

- This command is effective only when the JIS code system is selected.
- When the Kanji character mode is not selected, all character codes are processed one byte at a time as ASCII code.
- Kanji character mode is not selected when the power is turned on.

For Simplified Chinese/Traditional Chinese / Korean model:

- When the Kanji character mode is not selected, all character codes are processed one byte at a time as ASCII code.
- Kanji character mode is selected when the power is turned on.

[Reference] FS &(Select Kanji character mode), FS C(Select Kanji character code system)

FS ! n

[Name] Set print mode(s) for Kanji characters

[Format] ASCII FS ! n
Hex 1C 21 n
Decimal 28 33 n

[Range] $0 \leq n \leq 255$

[Description] Sets the print mode for Kanji characters, using n as follows:

bit	Off/On	Hex	Decimal	Function
0	-	-	-	Undefined
1	-	-	-	Undefined

D347 instruction manual

2	Off	00	0	Double-width mode is OFF.
	On	04	4	Double-width mode is ON.
3	Off	00	0	Double-height mode is OFF.
	On	08	8	Double-height mode is ON.
4	-	-	-	Undefined.
5	-	-	-	Undefined.
6	-	-	-	Undefined.
7	Off	00	0	Underline mode is OFF.
	On	80	128	Underline mode is ON.

- [Details]
- When both double-width and double-height modes are set (including right- and left-side character spacing), quadruple-size characters are printed.
 - The printer can underline all characters (including right- and left-side character spacing), but cannot underline the space set by HT and 90° clockwise-rotated characters.
 - The thickness of the underline is that specified by FS -, regardless of the character size.
 - When some of the characters in a line are double or more height, all the characters on the line are aligned at the baseline.
 - It is possible to emphasize the Kanji character using FS W or GS !; the setting of vthe last received command is effective.
 - It is possible to turn underline mode on or off using FS -, and the setting of the last received command is effective.

[Default] n=0

[Reference] FS -(Turn underline mode on/off for Kanji character), GS !(Select character size)

FS - n

[Name] Turn underline mode on/off for Kanji characters

[Format] ASCII FS - n
Hex 1C 2D n
Decimal 28 45 n

[Range] $0 \leq n \leq 2$

[Description] Turns underline mode for Kanji characters on or off, based on the following values of n for both receipt and slip.

n	Function
0	Turns off underline mode for Kanji characters
1	Turns on underline mode for Kanji characters (1-dot thick)
2	Turns on underline mode for Kanji characters (2-dot thick)

- [Details]
- The printer can underline all characters (including right- and left-side

D347 instruction manual

character spacing), but cannot underline the space set by HT and 90° clockwise-rotated characters.

- After the underline mode for Kanji characters is turned off by setting n to 0, underline printing is no longer executed, but the previously specified underline thickness is not changed. The default underline thickness is 1 dot.
- It is possible to turn underline mode on or off using FS !, and the last received command is effective.
- When the slip paper is selected, the underline thickness is 1 dot even if n is 2 .

[Default] n=0

[Reference] FS !(Set print mode(s) for Kanji characters)

FS S n1 n2

[Name] Set left- and right-side Kanji character spacing

[Format] ASCII FS S n1 n2
Hex 1C 53 n1 n2
Decimal 28 83 n1 n2

[Range] $0 \leq n1 \leq 255$, $0 \leq n2 \leq 255$

[Description] Sets left- and right-side Kanji character spacing to n1 and n2, respectively. The left-side character spacing is $[n1 \times 0.125 \text{ mm}]$, and the right-side character spacing is $[n2 \times 0.125 \text{ mm}]$.

- [Details]
- This command sets the left- and right-side character spacing for normal-sized characters. When double-width mode is set, the left- and right-side character spacing is twice the normal value.
 - The spacing which is set with this command can be set independently in standard mode and in page mode.
 - In standard mode, the horizontal motion unit is used.

[Default] n1=0, n2=0

ESC R n

[Name] Select an international character set

[Format] ASCII ESC R n
Hex 1B 52 n
Decimal 27 82 n

[Range] $0 \leq n \leq 13$

[Description] Selects international character set n from the following table:

n	Character set
0	U. S. A.
1	France
2	Germany

D347 instruction manual

3	U. K.
4	Denmark I
5	Sweden
6	Italy
7	Spain I
8	Japan
9	Norway
10	Denmark II
11	Spain II
12	Latin America
13	Korea

[Default] n=0

ESC { n

[Name] Turns on/off upside-down printing mode

[Format] ASCII ESC { n
 Hex 1B 7B n
 Decimal 27 123 n

[Range] $0 \leq n \leq 255$

[Description] Turn upside-down printing mode on or off.

- When the LSB of n is 0, upside-down printing mode is turned off.
- When the LSB of n is 1, upside-down printing mode is turned on.

[Notes] • Only the lowest bit of n is valid. In upside-down printing mode, the printer rotates the line to be printed by 180° and then prints it.

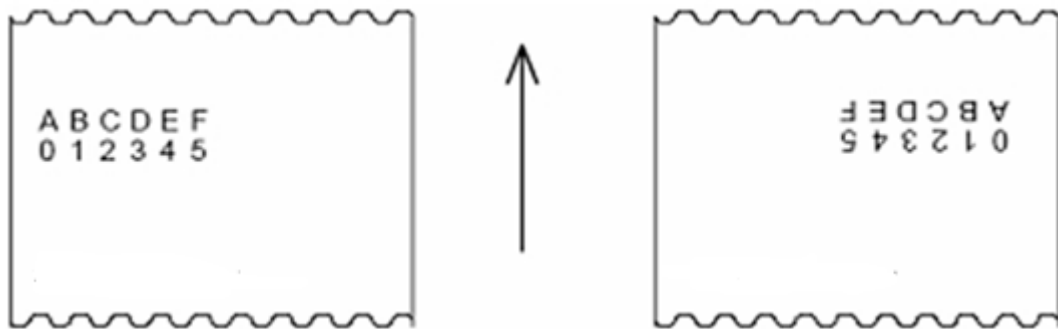

GS c

[Name] Select counter print mode

[Format] ASCII GS c
 Hex 1D 63
 Decimal 29 99

[Description] This command sets the number of digits to be printed.

4.3.3 Parameter setting command

ESC \$ nL nH

[Name]	Set absolute print position
[Format]	ASCII ESC \$ nL nH Hex 1B 24 nL nH Decimal 27 36 nL nH
[Range]	$0 \leq nL \leq 255, 0 \leq nH \leq 255$
[Description]	Sets the distance from the beginning of the line to the position at which subsequent characters are to be printed. <ul style="list-style-type: none"> • The distance from the beginning of the line to the print position is $[(nL + nH \times 256) \times 0.125 \text{ mm}]$.
[Details]	<ul style="list-style-type: none"> • Settings outside the specified printable area are ignored. • In standard mode, the horizontal motion unit (x) is used.
[Reference]	ESC \ (Set relative print position)

ESC \ nL nH

[Name]	Set relative print position
[Format]	ASCII ESC \ nL nH Hex 1B 5C nL nH Decimal 27 92 nL nH
[Range]	$0 \leq nL \leq 255, 0 \leq nH \leq 255$
[Description]	Sets the print starting position based on the current position using horizontal or vertical motion units. <ul style="list-style-type: none"> • This command sets the distance from the current position to $[(nL + nH \times 256) \times 0.125 \text{ mm}]$
[Notes]	<ul style="list-style-type: none"> • Any setting that exceeds the printable area is ignored. • When pitch N is specified to the right: $nL + nH \times 256 = N$ When pitch N is specified to the left (the negative direction), use the complement of 65536. When pitch N is specified to the left: $nL + nH \times 256 = 65536 - N$ • In standard mode, the horizontal motion unit is used.
[Reference]	ESC \$ (Set absolute print position)

ESC D n1...nk NULL

[Name]	Set horizontal tab positions
[Format]	ASCII ESC D n1 ... nk NULL Hex 1B 44 n1... nk 00 Decimal 27 68 n1... nk 0

D347 instruction manual

[Range] $0 \leq nL \leq 255$, $0 \leq k \leq 8$

[Description] Set horizontal tab positions.

- n specifies the column number for setting a horizontal tab position from the beginning of the line.
- k indicates the total number of horizontal tab positions to be set.

[Notes] • The horizontal tab position is stored as a value of [character width \times n] measured from the beginning of the line. The character width includes the right-side character spacing, and double-width characters are set with twice the width of normal characters.

- This command cancels the previous horizontal tab settings.
- When setting $n = 8$, the print position is moved to column 9 by

sending HT.

- Up to 32 tab positions ($k = 32$) can be set. Data exceeding 32 tab positions is processed as normal data.
- Transmit [n]k in ascending order and place a NUL code 0 at the end. When [n]k is less than or equal to the preceding value [n]k-1, tab setting is finished and the following data is processed as normal data.
- ESC D NUL cancels all horizontal tab positions.
- The previously specified horizontal tab positions do not change, even if the character width changes.

[Default] The default tab positions are at intervals of 8 characters (columns 9, 17, 25...) for Font A (12 \times 24).

[Reference] HT (Horizontal tab)

ESC 2

[Name] Select default line spacing

[Format]	ASCII	ESC	2
	Hex	1B	32
	Decimal	27	50

[Description] Selects 3.75 mm (30 \times 0.125 mm) line spacing.

[Notes] The line spacing can be set independently in standard mode.

[Reference] ESC 3 (Set line spacing)

ESC 3 n

[Name] Set line spacing

[Format]	ASCII	ESC	3	n
	Hex	1B	33	n
	Decimal	27	51	n

[Range] $0 \leq n \leq 255$

[Description] Sets the line spacing to [n \times 0.125 mm].

[Notes] The line spacing can be set independently in standard mode.

[Default] ESC 2(Select default line spacing)

D347 instruction manual

ESC SP n

[Name]	Set right-side character spacing
[Format]	ASCII ESC SP n Hex 1B 20 n Decimal 27 32 n
[Range]	$0 \leq n \leq 255$
[Description]	Sets the character spacing for the right side of the character to $[n \times 0.125 \text{ mm}]$.
[Details]	<ul style="list-style-type: none">• The right-side character spacing for double-width mode is twice the normal value. When characters are enlarged, the right-side character spacing is n times normal value.• This command does not affect the setting of Kanji characters.• This command sets values independently in each mode (standard and page modes).
[Default]	n=0

ESC a n

[Name]	Select justification
[Format]	ASCII ESC a n Hex 1B 61 n Decimal 27 97 n
[Range]	$0 \leq n \leq 2$
[Description]	Align all the data in one line to the specified position. n selects the justification as follows:

n	Justification
0	Left justification
1	centering
2	Right justification

[Notes]	The command is enabled only when processed at the beginning of the line in standard mode.
[Default]	n=0

GS L nL nH

[Name]	Set left margin
[Format]	ASCII GS L nL nH Hex 1D 4C nL nH Decimal 29 76 nL nH
[Range]	$0 \leq nL \leq 255, 0 \leq n \leq 255$
[Description]	Sets the left margin using nL and nH. <ul style="list-style-type: none">• The left margin is set to $[(nL + nH \times 256) \times 0.125 \text{ mm}]$.

D347 instruction manual

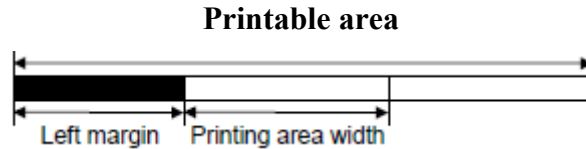

- [Notes]
- This command is effective only when processed at the beginning of the line in standard mode.
 - If the setting exceeds the printable area, the maximum value of the printable area is used.
 - The left margin can be set only with each 8 bits by this command when the raster bit image command (GS v 0) is executed. If the left margin to be intended to set cannot be divided by eight, omit the remainder.
- Example:
 If $(nL + nH \times 256) = 20$, the setting value is 16.
- [Default] $nL=0, nH=0$
- [Reference] GS W(Set printing area width)

GS :

[Name] Start/end macro definition

[Format]

ASCII	GS :
Hex	1D 3A
Decimal	29 58

[Description] Starts or ends macro definition.

- [Notes]
- Macro definition starts when this command is received during normal operation.
 - Macro definition ends when this command is received during macro definition.
 - Macro is not defined when the power is turned on.

4.3.4 Graphics / image print command

GS v 0 m xL xH yL yH d1...dk

[Name] Print raster bit image

[Format]

ASCII	GS v 0 m xL xH yL yH d1...dk
Hex	1D 76 30 m xL xH yL yH d1...dk
Decimal	29 118 48 m xL xH yL yH d1...dk

[Range]

$0 \leq m \leq 3, 1 \leq xL \leq 128$
 $xH=0, \text{ where } 1 \leq (xL + xH*256) \leq 128$
 $0 \leq yL \leq 255$
 $1 \leq yH \leq 15, \text{ where } 1 \leq (yL + yH*256) \leq 4095$
 $0 \leq d \leq 255$
 $k = (xL + xH*256) * (yL + yH*256) \quad (k \neq 0)$

D347 instruction manual

[Description] Select raster bit-image mode. The value of m selects the mode, as follows :

m	mode	Vertical Dot Density	Horizontal Dot Density
0	Normal	203.2dpi	203.2dpi
1	Double-width	203.2dpi	101.6dpi
2	Double-height	101.6dpi	203.2dpi
3	Quadruple	101.6dpi	101.6dpi

(dpi: dots per 25.4mm{1 inch})

- [Notes]
- xL, xH, select the number of data bytes ($xL+xH \times 256$) in the horizontal direction for the bit image.
 - yL, yH, select the number of data bits ($yL+yH \times 256$) in the vertical direction for the bit image.
 - In standard mode, this command is effective only when there is no data in the print buffer.
 - This command is not affected by print modes (character size, emphasized, double-strike, upside-down, underline, white/black reverse printing, etc.) for raster bit image.

- [Details]
- If the printing area width set by GS L and GS W is less than the minimum width, the printing area is extended to the minimum width only on the line in question. The minimum width means 1 dot in normal ($m=0, 48$) and double-height ($m=2, 50$), 2 dots in double-width ($m=1, 49$) and quadruple ($m=3, 51$) modes.
 - Data outside the printing area is read in and discarded on a dot-by-dot basis.
 - The position at which subsequent characters are to be printed for raster bit image is specified by HT (Horizontal Tab), ESC \$ (Set absolute print position), ESC \ (Set relative print position), and GS L (Set left margin). If the position at subsequent characters is to be printed is a multiple of 8.
 - The ESC a (Select justification) setting is also effective on raster bit images.
 - When this command is received during macro definition, the printer ends macro definition, and begins performing this command. The definition of this command should be cleared.
 - d indicates the bit-image data. Setting a bit to 1 prints a dot and setting it to 0 does not print a dot.

[Example] When $xL+xH \times 256=64$:

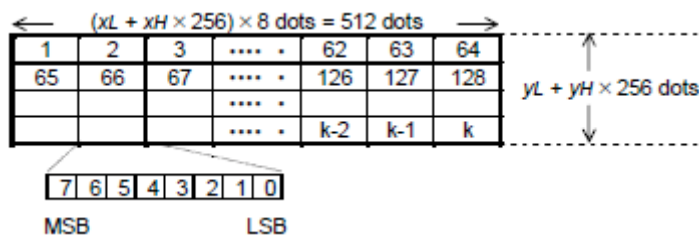

D347 instruction manual

FS P n m

[Name] Print NV bit image

[Format] ASCII FS p n m
 Hex 1C 70 n m
 Decimal 28 112 n m

[Range] $1 \leq n \leq 255$, $0 \leq m \leq 3$, $48 \leq m \leq 51$

[Description] Prints NV bit image n using the mode specified by m.

m	mode	Vertical Dot Density	Horizontal Dot Density
0,48	Normal	203.2dpi	203.2dpi
1,49	Double-width	203.2dpi	101.6dpi
2,50	Double-height	101.6dpi	203.2dpi
3,51	Quadruple	101.6dpi	101.6dpi

- [Details] • NV bit image is a bit image defined in non-volatile memory by FS q and printed by FS p.
- This command is not effective when the specified NV bit image has not been defined.
 - In standard mode, this command is effective only when there is no data in the print buffer.
 - This command is not affected by print modes (emphasized, double-strike, underline, character size, white/black reverse printing, or 90° rotated characters, etc.).
 - If the printing area width set by GS L and GS W for the NV bit image is less than one vertical line, the following processing is performed only on the line in question. However, in NV bit image mode, one vertical line means 1 dot in normal mode (m=0, 48) and in double-height mode (m=2, 50), and it means 2 dots in double-width mode (m=1, 49) and in quadruple mode (m=3, 51).
 - ① The printing area width is extended to the right in NV bit image mode up to one line vertically. In this case, printing does not exceed the printable area.
 - ② If the printing area width cannot be extended by one line vertically, the left margin is reduced to accommodate one line vertically.
 - If the downloaded bit-image to be printed exceeds one line, the excess data is not printed.
 - This command feeds dots (for the height n of the NV bit image) in normal and double-width modes, and (for the height $n \times 2$ of the NV bit image) in double-height and quadruple modes, regardless of the line spacing specified by ESC 2 or ESC 3.
 - After printing the bit image, this command sets the print position to the beginning of the line and processes the data that follows as normal data.

D347 instruction manual

GS * x y d1...d (x y 8)

- [Name] Define downloaded bit image
- [Format] ASCII GS * x y d1...d (x y 8)
 Hex 1D 2A x y d1...d (x y 8)
 Decimal 29 42 x y d1...d (x y 8)
- [Range] $1 \leq x \leq 255$, $1 \leq y \leq 48$ ($x*y \leq 1536$), $0 \leq d \leq 255$
- [Description] Defines a downloaded bit image using the number of dots specified by x and y.
- x specifies the number of dots in the horizontal direction.
 - y specifies the number of dots in the vertical direction.
- [Notes]
- The number of dots in the horizontal direction is $x \times 8$; in the vertical direction it is $y \times 8$.
 - If $x \times y$ is out of the specified range, this command is disabled.
 - The d indicates bit-image data. Data (d) specifies a bit printed as 1 and not printed as 0.
 - The downloaded bit image definition is cleared when:
 - ① _ ESC @ is executed.
 - ② _ ESC & is executed.
 - ③ _ Printer is reset or the power is turned off.
 - The following figure shows the relationship between the downloaded bit image and the printed data.

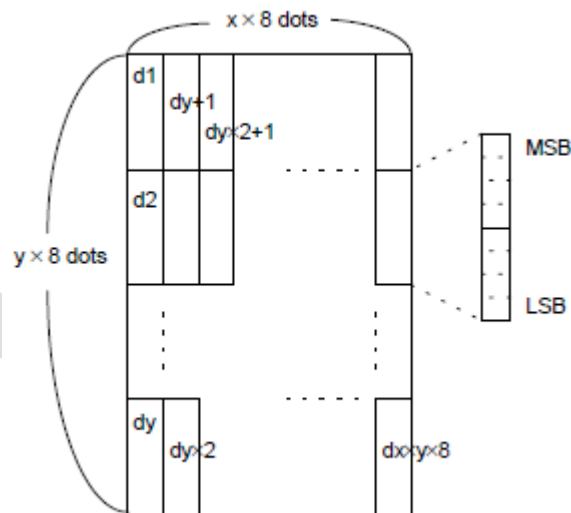

4.3.5 Bar code print command

GS h n

- [Name] Select bar code height
- [Format] ASCII GS h n
 Hex 1D 68 n

D347 instruction manual

Decimal 29 104 n
 [Range] $0 \leq n \leq 240$
 [Description] Select the height of the bar code.
 n specifies the number of dots in the vertical direction.
 [Reference] GS k (Print bar code)

GS w n

[Name] Set code width
 [Format] ASCII GS w n
 Hex 1D 77 n
 Decimal 29 119 n
 [Range] $1 \leq n \leq 4$
 [Description] Set the horizontal size of the bar code.
 n specifies the bar code width as follows:

n	Module Width (mm) for Multi-level Bar Code	Binary-level Bar Code	
		Thin Element Width (mm)	Thick Element Width (mm)
1	0.125	0.125	0.25
2	0.25	0.25	0.50
3	0.375	0.375	0.75
4	0.50	0.50	1.0

[Notes] • Multi-level bar codes are as follows:
 UPC-A, UPC-E, JAN13 (EAN13), JAN8 (EAN8), CODE93, CODE128
 • Binary-level bar codes are as follows:
 CODE39, ITF, CODABAR

[Default] n=2
 [Reference] GS k(Print bar code)

GS H n

[Name] Select printing position for HRI characters
 [Format] ASCII GS H n
 Hex 1D 48 n
 Decimal 29 72 n
 [Range] $0 \leq n \leq 2$
 [Description] Select the printing position of HRI characters when printing a bar code.
 n selects the printing position as follows:

n	Printing position
0	Not printed
1	Above the bar code
2	Below the bar code
3	Both above and below the bar code

D347 instruction manual

- [Notes] • HRI indicates Human Readable Interpretation.
 • HRI characters are printed using the font specified by GS f.
- [Default] n=0
- [Reference] GS k(Print bar code)

GS f n

- [Name] Select font for Human Readable Interpretation (HRI) characters
- [Format] ASCII GS f n
 Hex 1D 66 n
 Decimal 29 102 n
- [Range] n=0, 1
- [Description] Selects a font for the HRI characters used when printing a bar code.
 n selects a font from the following table:

n	Font
0	Font A(12*24)
1	Font B(8*16)

- [Notes] • HRI indicates Human Readable Interpretation.
 • HRI characters are printed at the position specified by GS H.
- [Default] n=0
- [Reference] GS k (Print bar code)

GS p n

- [Name] Set HRI characters Alignment
- [Format] ASCII GS p n
 Hex 1D 50 n
 Decimal 29 90 n
- [Range] n=0, 1, 2
- [Description] n selects a Alignment from the following table:

n	Alignment
0	Left Justified
1	Center Justified
2	Right Justified

- [Default] n=0
- [Reference] GS k (Print bar code)

GS k

- [Name] Print bar code
- [Format I] ASCII GS k m d1···dk NULL
 Hex 1D 6B m d1···dk 00
 Decimal 29 107 m d1···dk 0

D347 instruction manual

[Format II] ASCII GS k m n d1...dk NULL
 Hex 1D 6B m n d1...dk 00
 Decimal 29 107 m n d1...dk 0

[Range] Format I: $0 \leq m \leq 9$ (k and d depend on the bar code system used)
 Format II: $65 \leq m \leq 76$ (n and d depend on the bar code system used)

[Description] Selects a bar code system and prints the bar code.
 m selects a bar code system as follows:

m	Bar Code System	Number of Characters	Remarks	
①	0	UPC-A	$11 \leq k \leq 12$	$48 \leq d \leq 57$
	1	UPC-E	$11 \leq k \leq 12$	$48 \leq d \leq 57$
	2	JAN13(EAN13)	$12 \leq k \leq 13$	$48 \leq d \leq 57$
	3	JAN8(EAN8)	$7 \leq k \leq 8$	$48 \leq d \leq 57$
	4	CODE39	$1 \leq k$	$48 \leq d \leq 57, 65 \leq d \leq 90,$ $32, 36, 37, 43, 45, 46, 47$
	5	ITF	$1 \leq k$ (even number)	$48 \leq d \leq 57$
	6	CODABAR	$1 \leq k$	$48 \leq d \leq 57, 65 \leq d \leq 68,$ $36, 43, 45, 46, 47, 58$
	7	Standard EAN13	$12 \leq k \leq 13$	$48 \leq d \leq 57$
	8	Standard EAN8	$7 \leq k \leq 8$	$48 \leq d \leq 57$
	9	PDF417	$1 \leq k \leq 255$	$0 \leq d \leq 255$
②	65	UPC-A	$11 \leq n \leq 12$	$48 \leq d \leq 57$
	66	UPC-E	$11 \leq n \leq 12$	$48 \leq d \leq 57$
	67	JAN13(EAN13)	$12 \leq n \leq 13$	$48 \leq d \leq 57$
	68	JAN8(EAN8)	$7 \leq n \leq 8$	$48 \leq d \leq 57$
	69	CODE39	$1 \leq n \leq 255$	$48 \leq d \leq 57, 65 \leq d \leq 90,$ $32, 36, 43, 45, 46, 47$
	70	ITF	$1 \leq n \leq 255$ (even number)	$48 \leq d \leq 57$
	71	CODABAR	$1 \leq n \leq 255$	$48 \leq d \leq 57, 65 \leq d \leq 68,$ $36, 43, 45, 46, 47, 58$
	72	CODE93	$1 \leq n \leq 255$	$0 \leq d \leq 127$
	73	CODE128	$1 \leq n \leq 255$	$0 \leq d \leq 127$
	74	Standard EAN13	$12 \leq n \leq 13$	$48 \leq d \leq 57$
	75	Standard EAN8	$7 \leq n \leq 8$	$48 \leq d \leq 57$
	76	PDF417	$1 \leq n \leq 255$	$0 \leq d \leq 255$

[Notes for ①]:

- ◆ This command ends with a NUL code.
- ◆ When the bar code system used is UPC-A or UPC-E, the printer prints the bar code data after receiving 12 bytes of bar code data and processes the following data as normal data.

D347 instruction manual

- ◆ When the bar code system used is JAN13 (EAN13), the printer prints the bar code after receiving 13 bytes of bar code data and processes the following data as normal data.
- ◆ When the bar code system used is JAN8 (EAN8), the printer prints the bar code after receiving 8 bytes of bar code data and processes the following data as normal data.
- ◆ The number of data for the ITF bar code must be even numbers. When an odd number of bytes of data is input, the printer ignores the last received data.

[Notes for ②]:

- ▲ n indicates the number of bar code data bytes, and the printer processes n bytes from the next character data as bar code data.
- ▲ If n is outside the specified range, the printer stops command processing and processes the following data as normal data.

[Notes in standard mode]:

- ▲ If d is outside the specified range, the printer only feeds paper and processes the following data as normal data.
- ▲ If the horizontal size exceeds printing area, the printer only feeds the paper. This command feeds as much paper as is required to print the bar code, regardless of the line spacing specified by ESC 2 or ESC 3.
- ▲ This command is enabled only when no data exists in the print buffer. When data exists in the print buffer, the printer processes the data following m as normal data.
- ▲ After printing the bar code, this command sets the print position to the beginning of the line.
- ▲ This command is not affected by print modes (emphasized, double-strike, underline, character size, white/black reverse printing, or 90° rotated character, etc.), except for upside-down printing mode.

[When thermal labels are used]:

- ◆ If the height of the bar code will not fit on the current label, the excess is printed on the next label.

[When CODE93 (m=72) is used] :

- ◆ The printer prints an HRI character () as the start character at the beginning of the HRI character string.
- ◆ The printer prints an HRI character () as a stop character at the end of the HRI character string.
- ◆ The printer prints HRI characters (+ an alphabetic character) as a control character (<00>H to <1F>H and <7F>H):

Control character			HRI Character	Control character			HRI Character
ASCII	Hex	Decimal		ASCII	Hex	Decimal	
NUL	00	0	■U	DLE	10	16	■P
SOH	01	1	■A	DC1	11	17	■Q
STX	02	2	■B	DC2	12	18	■R
ETX	03	3	■C	DC3	13	19	■S

D347 instruction manual

EOT	04	4	■D	DC4	14	20	■T
ENQ	05	5	■E	NAK	15	21	■U
ACK	06	6	■F	SYN	16	22	■V
BEL	07	7	■G	ETB	17	23	■W
BS	08	8	■H	CAN	18	24	■X
HT	09	9	■I	EN	19	25	■Y
LF	0A	10	■J	SUB	1A	26	■Z
VT	0B	11	■K	ESC	1B	27	■A
FF	0C	12	■L	FS	1C	28	■B
CR	0D	13	■M	GS	1D	29	■C
SO	0E	14	■N	RS	1E	30	■D
SI	0F	15	■O	US	1F	31	■E
				DEL	7F	127	■T

When CODE128 (m=73) is used:

Refer to Appendix C for the information for the CODE128 bar code and its code table.

When using CODE128 in this printer, take the following points into account for data transmission:

- ① The top of the bar code data string must be the code set selection character (CODE A, CODE B, or CODE C), which selects the first code set.
- ② Special characters are defined by combining two characters "{" and one character. The ASCII character "{" is defined by transmitting "{" twice consecutively.

Specific character	Transmit data		
	ASCII	Hex	Decimal
SHIFT	{S	7B,53	123, 83
CODE A	{A	7B,41	123, 65
CODE B	{B	7B,42	123, 66
CODE C	{C	7B,43	123, 67
FNC1	{1	7B,31	123, 49
FNC2	{2	7B,32	123, 50
FNC3	{3	7B,33	123, 51
FNC4	{4	7B,34	123, 52
"{"	{{	7B,7B	123, 123

〔Example〕 Example data for printing "No. 123456".

In this example, the printer first prints "No." using CODE B, then prints the following numbers using CODE C.

GS k 73 10 123 66 78 111 46 123 67 12 34 56



- If the top of the bar code data is not the code set selection character, the printer stops command processing and processes the following data as normal data.
- If the combination of “{” and the following character does not apply any special character, the printer stops command processing and processes the following data as normal data.
- If the printer receives characters that cannot be used in the special code set, the printer stops command processing and processes the following data as normal data.
- The printer does not print HRI characters that correspond to the shift characters or code set selection characters.
- HRI character for the function character is space.
- HRI characters for the control character (<00>H to <1F>H and <7F>H) are space.

[Others] Be sure to keep spaces on both right and left sides of a bar code. (Spaces are different depending on the types of the bar code.)

[Reference] GS H, GS f, GS h, GS w, Appendix C

4.3.6 Printer Status Feedback

DLE EOT n

[Name]	Real-time status transmission			
[Format]	ASCII	DLE	EOT	n
	Hex	10	04	n
	Decimal	16	4	n

[Range] n=1, 2, 3, 4

[Description] Transmits the selected printer status specified by n in real-time, according to the following parameters:

- n = 1: Transmit printer status
- n = 2: Transmit offline status
- n = 3: Transmit error status
- n = 4: Transmit paper roll sensor status

[Details]

- The printer transmits the current status. Each status item is represented by one-byte of data.
- The printer transmits the status without confirming whether the host computer can receive data.

D347 instruction manual

- The printer executes this command upon receiving it.
- This command is executed even when the printer is offline, the receive buffer is full, or there is an error status with a serial interface model.

n=1 Printer status

Bit	Off/On	Hex	Decimal	Function
0	Off	00	0	Not used.Fixed to Off.
1	On	02	2	Not used.Fixed to On.
2	On	04	4	Not used.Fixed to On.
3	Off	00	0	Online.
	On	08	8	Offline.
4	On	10	16	Not Used.Fixed to On.
5	Off	00	0	Does not Wait for online error recovery
	On	20	32	Waits for online error recovery.
6	Off	00	0	FEED button is Off.
	On	40	64	FEED button is On.
7	Off	00	0	Not used.Fixed to Off.

n=2 Offline status

Bit	Off/On	Hex	Decimal	Function
0	Off	00	0	Not used.Fixed to Off.
1	On	02	2	Not used.Fixed to On.
2	Off	00	0	Platen is closed.
	On	04	4	Platen is open.
3	Off	00	0	Paper is not being fed by using the FEED button.
	On	08	8	Paper is being fed by the Feed button.
4	On	10	16	Not Used.Fixed to On.
5	Off	00	0	No paper-end stop.
	On	20	32	Printing is being stopped.
6	Off	00	0	No error.
	On	40	64	Error occurred.
7	Off	00	0	Not used.Fix to Off.

Bit3: Becomes same as bit 6 of Printer status(n=1),except during a marco execution with the FEED button.

Bit5: Becomes on when the paper end sensor detects paper end and printing stops.

n=3 Error status

Bit	Off/On	Hex	Decimal	Function
0	Off	00	0	Not used.Fixed to Off.
1	On	02	2	Not used.Fixed to On.
2	Off	00	0	No mechanical error.
	On	04	4	Mechanical error has occurred.
3	Off	00	0	No autocutter error.
	On	08	8	Autocutter error occurred.
4	On	10	16	Not Used.Fixed to On.
5	Off	00	0	No unrecoverable error.

D347 instruction manual

	On	20	32	Unrecoverable error occurred.
6	Off	00	0	No auto-recoverable error.
	On	40	64	Auto recoverable error occurred.
7	Off	00	0	Not used.Fix to Off.

Bit6: Bit 6 is on when printing is stopped due to high print head temperature until the print head temperature drops sufficiently or when the paper roll cover is opened during printing.

n=4 Continuous paper sensor status

Bit	Off/On	Hex	Decimal	Function
0	Off	00	0	Not used.Fixed to Off.
1	On	02	2	Not used.Fixed to On.
2,3	Off	00	0	Paper roll near-end sensor:paper adequate.
	On	0C	12	Paper near-end is detected by the paper roll near-end sensor.
4	On	10	16	Not used.Fix to on.
5,6	Off	00	0	Paper roll sensor:Paper present.
	On	60	96	Paper roll end detected by paper roll sensor.
7	Off	00	0	Not used.Fixed to Off.

[Reference] DLE ENQ (Real-time request to printer)

DLE ENQ n

[Name] Real-time request to printer

[Format] ASCII DLE ENQ n
 Hex 10 05 n
 Decimal 16 5 n

[Range] $1 \leq n \leq 2$

[Description] Respond to a request from the host computer. n specifies the requests as follows:

n	Request
1	Recover from an error and restart printing from the line where the error occurred.
2	Recover from an error aft clearing the receive and print buffers.

[Details] • This command is effective only when an autocutter error, a BM detecting error or a platen-open error occurs.

• The printer starts processing data upon receiving this command.

[Notes] The status is also transmitted whenever the data sequence of <10>H<05>H<n> ($1 \leq n \leq 2$) is received.

Example:

In ESC □ m nL nH dk, d1 = <10>H, d2 = <05>H, d3 = <01>H

• This command should not be contained within another command that consists of two or more bytes.

Example:

If you attempt to transmit ESC 3 n to the printer, but DTR (DSR for the

D347 instruction manual

host computer) goes to MARK before n is transmitted, and DLE ENQ 2 interrupts before n is received, the code <10>H for DLE ENQ 2 is processed as the code for ESC 3 <10>H.

[Reference] DLE EOT (Real-time status transmission)

GS r n

[Name] Transmit status
 [Format] ASCII GS r n
 Hex 1D 72 n
 Decimal 29 114 n

[Range] n = 1, 49

[Description] Transmits the status specified by n as follows:

n	Function
1,49	Transmits paper sensor status

- [Notes]
- When using a serial interface:
 When DTR/DSR control is selected, the printer transmits only 1 byte after confirming the host is ready to receive data (DSR signal is SPACE). If the host computer is not ready to receive data (DSR signal is MARK), the printer waits until the host is ready.
 When XON/XOFF control is selected, the printer transmits only 1 byte without confirming the condition of the DSR signal.
 - This command is executed when the data in the receive buffer is developed. Therefore, there may be a time lag between receiving this command and transmitting the status, depending on the receive buffer status.
 - When Auto Status Back (ASB) is enabled using GS a, the status transmitted by GS r and the ASB status must be differentiated using the table in Appendix C.
 - The status types to be transmitted are shown below:

Paper sensor status (n = 1, 49):

Bit	Off/On	Hex	Decimal	Status for ASB
0,1	Off	00	0	Paper roll near-end sensor: paper adequate.
	On	03	3	Paper roll near-end sensor: paper near end.
2,3	Off	00	0	Paper roll end sensor: paper present.
	On	0C	12	Paper roll end sensor: paper not present.
4	Off	10	16	Not used.Fixed to Off.
5, 6	--	--	--	Undefined.
7	Off	00	0	Not used.Fixed to Off.

Bits 2 and 3: When the paper end sensor detects a paper end, the printer goes offline and does not execute this command. Therefore, bits 2 and 3 do not transmit the status of paper end.

[Reference] DLE EOT.

4.3.7 Cutter Control

GS V m/GS V m n

[Name] Select cut mode and cut paper

[Format ①] ASCII GS V m
 Hex 1D 56 m
 Decimal 29 86 m

[Format ②] ASCII GS V m n
 Hex 1D 56 m n
 Decimal 29 86 m n

[Range] ①m=1, 49 ②m=66, 0≤n≤255

[Description] Selects a mode for cutting paper and executes paper cutting.

m	Print mode
1,49	Cuts paper
66	Feeds paper (cutting position+[n*0.125 mm]),and cuts the paper.

[Details] • This command is effective only when processed at the beginning of a line.

- Cutting status (full or partial) is different, depending on the autocutter type that is installed in each printer model:
 For ① Full cut.
 For ② :When n = 0, the printer feeds the paper to the cutting position and cuts it. When n ≠ 0, the printer feeds the paper to (cutting position + [n × 0.125 mm{0.0049"}]) and cuts it.

ESC i

[Name] Full cut paper

[Format] ASCII ESC i
 Hex 1B 69
 Decimal 27 105

[Description] Full cut paper.

ESC m

[Name] Partial cut paper

[Format] ASCII ESC m
 Hex 1B 6D
 Decimal 29 109

[Description] Partial cut paper.

5. Storage

- 1) During transport or storage, protect the device by storing it in conductive sponge, aluminum foil, etc.
- 2) Do not short-circuit any of the output pins with the power supply: Short-circuiting an output pin with a low-impedance power supply may cause heat damage due to excess current or may melt the bonding wire.
- 3) Be sure to connect the devices with the specified cables: Improper connection may cause fire or shock.
- 4) Never disassemble or modify this product. Tampering with this product may result in injury, fire, or electric shock.
- 5) Be sure to set this equipment on a firm, stable, horizontal surface. Product may break or cause injury if it falls.
- 6) Do not place heavy objects on top of this product. Never stand or lean on this product. Equipment may fall or collapse, causing breakage and possible injury.
- 7) Do not use in locations subject to high humidity or dust levels. Excessive humidity and dust may cause equipment damage, fire, or shock.
- 8) To ensure safety, please unplug this product prior to leaving it unused for an extended period.

6. Appendix

Appendix A : Miscellaneous notes

A.1 Notes on Printing and Paper Feeding

1) Because the printer is a line printer, it automatically feeds paper after printing the data.

Therefore, when the line spacing for one line is set to a smaller value than the print data, paper may be fed more than the set amount just to print the data.

For example, when the line spacing for one line is set to 10 dots (10/180 inches) and only paper feeding is executed, paper is fed for 10 dots; however, if bit-image characters are printed, paper is fed for 24 dots. (Refer to Table A.1.)

When only rotated characters are printed on one line, paper feeding is executed as shown in Table A.1.

Table A.1 Paper Feeding Amount

		Required Paper Feeding Amount(dots)
Normal Characters	Font A	24*number of times enlarged vertically
	Font B	17* number of times enlarged vertically

D347 instruction manual

	Kanji	24* number of times enlarged vertically
Rotated Characters	Font A	12* number of times enlarged vertically
	Font B	9* number of times enlarged vertically
	Kanji	24* number of times enlarged vertically
Bit image (ESC *)		24

2) When the printer goes to the standby (data-waiting) state during printing, it temporarily stops printing and feeding paper. When data is transmitted and printing is executed, paper may shift 1 to 3 dots from the print starting position, which especially affects bit-image printing.

3) Interval of autcutting operation in the receipt section. For driving the autocutter of the receipt section, take the interval as a minimum of 10 lines of printing or paper feeding (to prevent small pieces of cut paper from dropping into the autocutter).

A.2 Notes on Connecting the External Power Supply

Connect the external power supply to the power supply connector of the printer. Then plug in the external power supply and turn it on if necessary. Be sure not to connect the external power supply with the wrong polarity. If it is connected incorrectly, the internal circuit fuse of the printer may be blown, or the external power supply may be damaged.

The power supply voltage is within the range of $24 \pm 10\%$ V. If the power supply voltage drops outside of the range above during printing, the printer stops printing and waits until the voltage returns to normal and then automatically begins printing again.

When either a high or low voltage error occurs, turn off the power as soon as possible.

Appendix B : CODE128 BAR CODE

B.1 Description of the CODE128 Bar Code

In CODE128 bar code system, it is possible to represent 128 ASCII characters and 2-digit numerals using one bar code character that is defined by combining one of the 103 bar code characters and 3 code sets. Each code set is used for representing the following characters:

- (1) Code set A: ASCII characters 00H to 5FH
- (2) Code set B: ASCII characters 20H to 7FH
- (3) Code set C: 2-digit numeral characters using one character (100 numerals from 00 to 99) The following special characters are also available in CODE128:
- (4) SHIFT characters

In code set A, the character just after SHIFT is processed as a character for

D347 instruction manual

code set B. In code set B, the character just after SHIFT is processed as the character for code set A. SHIFT characters cannot be used in code set C.

(5) Code set selection character (CODE A, CODE B, CODE C)

This character switches the following code set to code set A, B, or C.

(6) Function character (FNC1, FNC2, FNC3, FNC4)

The usage of function characters depends on the application software. In code set C, only FNC1 is available.

B.2 Code Tables

Printable characters in code set A

Character	Transmit Data		Character	Transmit Data		Character	Transmit Data	
	Hex	Decimal		Hex	Decimal		Hex	Decimal
NUL	00	0	(28	40	P	50	80
SOH	01	1)	29	41	Q	51	81
STX	02	2	*	2A	42	R	52	82
ETX	03	3	+	2B	43	S	53	83
EOT	04	4	,	2C	44	T	54	84
ENQ	05	5	-	2D	45	U	55	85
ACK	06	6	.	2E	46	V	56	86
BEL	07	7	/	2F	47	W	57	87
BS	08	8	0	30	48	X	58	88
T	09	9	1	31	49	Y	59	89
LF	0A	10	2	32	50	Z	5A	90
VT	0B	11	3	33	51	[5B	91
FF	0C	12	4	34	52	\	5C	92
CR	0D	13	5	35	53]	5D	93
SO	0E	14	6	36	54	^	5E	94
SI	0F	15	7	37	55	_	5F	95
DLE	10	16	8	38	56	FNC1	7B,31	123,49
DC1	11	17	9	39	57	FNC2	7B,32	123,50
DC2	12	18	:	3A	58	FNC3	7B,33	123,51
DC3	13	19	;	3B	59	FNC4	7B,34	123,52
DC4	14	20	<	3C	60	SHIFT	7B,53	123,83
NAK	15	21	=	3D	61	CODEB	7B,42	123,66
SYN	16	22	>	3E	62	CODEC	7B,43	123,67
ETB	17	23	?	3F	63			
CAN	18	24	@	40	64			
EM	19	25	A	41	65			
SUB	1A	26	B	42	66			
ESC	1B	27	C	43	67			
FS	1C	28	D	44	68			

D347 instruction manual

GS	1D	29	E	45	69			
RS	1E	30	F	46	70			
US	1F	31	G	47	71			
SP	20	32	H	48	72			
!	21	33	I	49	73			
“	22	34	J	4A	74			
#	23	35	K	4B	75			
\$	24	36	L	4C	76			
%	25	37	M	4D	77			
&	26	38	N	4E	78			
'	27	39	O	4F	79			

Printable characters in code set B

Character	Transmit Data		Character	Transmit Data		character	Transmit Data	
	Hex	Decimal		Hex	Decimal		Hex	Decimal
SP	20	32	H	48	72	p	70	112
!	21	33	I	49	73	q	71	113
”	22	34	J	4A	74	r	72	114
#	23	35	K	4B	75	s	73	115
\$	24	36	L	4C	76	t	74	116
%	25	37	M	4D	77	u	75	117
&	26	38	N	4E	78	v	76	118
'	27	39	O	4F	79	w	77	119
(28	40	P	50	80	x	78	120
)	29	41	Q	51	81	y	79	121
*	2A	42	R	52	82	z	7A	122
+	2B	43	S	53	83	{	7B	123
,	2C	44	T	54	84		7C	124
_	2D	45	U	55	85	}	7D	125
.	2E	46	V	56	86	-	7E	126
/	2F	47	W	57	87	DEL	7F	127
0	30	48	X	58	88	FNC1	7B,31	123,49
1	31	49	Y	59	89	FNC2	7B,32	123,50
2	32	50	Z	5A	90	FNC3	7B,33	123,51
3	33	51	[5B	91	FNC4	7B,34	123,52
4	34	52	\	5C	92	SHIFT	7B,53	123,83
5	35	53]	5D	93	CODEA	7B,41	123,66
6	36	54	^	5E	94	CODEC	7B,43	123,67
7	37	55	_	5F	95			
8	38	56	`	60	96			
9	39	57	a	61	97			
:	3A	58	b	62	98			
;	3B	59	c	63	99			
<	3C	60	d	64	100			

D347 instruction manual

=	3D	61	e	65	101			
>	3E	62	f	66	102			
?	3F	63	g	67	103			
@	40	64	h	68	104			
A	41	65	i	69	105			
B	42	66	j	6A	106			
C	43	67	k	6B	107			
D	44	68	l	6C	108			
E	45	69	m	6D	109			
F	46	70	n	6E	110			
G	47	71	o	6F	111			

Printable characters in code set C

character	Transmit Data		character	Transmit Data		character	Transmit Data	
	Hex	Decimal		Hex	Decimal		Hex	Decimal
00	00	0	40	28	40	80	50	80
01	01	1	41	29	41	81	51	81
02	02	2	42	2A	42	82	52	82
03	03	3	43	2B	43	83	53	83
04	04	4	44	2C	44	84	54	84
05	05	5	45	2D	45	85	55	85
06	06	6	46	2E	46	86	56	86
07	07	7	47	2F	47	87	57	87
08	08	8	48	30	48	88	58	88
09	09	9	49	31	49	89	59	89
10	0A	10	50	32	50	90	5A	90
11	0B	11	51	33	51	91	5B	91
12	0C	12	52	34	52	92	5C	92
13	0D	13	53	35	53	93	5D	93
14	0E	14	54	36	54	94	5E	94
15	0F	15	55	37	55	95	5F	95
16	10	16	56	38	56	96	60	96
17	11	17	57	39	57	97	61	97
18	12	18	58	3A	58	98	62	98
19	13	19	59	3B	59	99	63	99
20	14	20	60	3C	60	FNC1	7B,31	123,49
21	15	21	61	3D	61	CODEA	7B,41	123,65
22	16	22	62	3E	62	CODEB	7B,42	123,66
23	17	23	63	3F	63			
24	18	24	64	40	64			
25	19	25	65	41	65			
26	1A	26	66	42	66			
27	1B	27	67	43	67			
28	1C	28	68	44	68			

D347 instruction manual

29	1D	29	69	45	69			
30	1E	30	70	46	70			
31	1F	31	71	47	71			
32	20	32	72	48	72			
33	21	33	73	49	73			
34	22	34	74	4A	74			
35	23	35	75	4B	75			
36	24	36	76	4C	76			
37	25	37	77	4D	77			
38	26	38	78	4E	78			
39	27	39	79	4F	79			

Appendix C : Switching Online and Offline

The printer changes from offline to online or from online to offline in the following instances:

- 1) When the power is turned on or during the self-test using the paper FEED button:

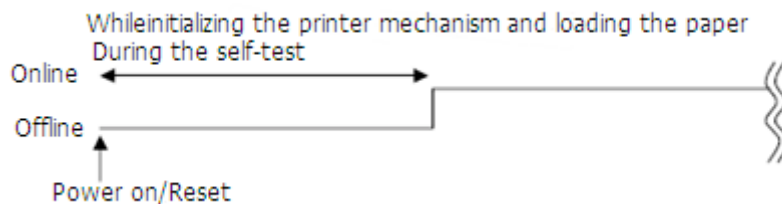

The printer is offline between the time when power is turned on (or the printer is reset) and when the printer is ready to receive data.

If ASB (Auto Status Back) is enabled, the printer transmits each status item such as when an error occurs. When the printer detects a status change with the sensors even if the printer is offline, the printer transmits the ASB.

If the sensor's status changes while the printer initializes as described above, the printer transmits the offline information with the cause unknown. If this occurs, wait until the printer process a change in the status or the printer comes online.

- 2) When the self-test is executed (by a command):

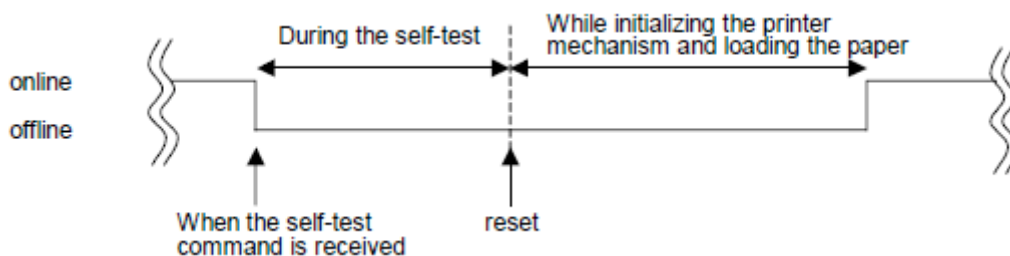

The printer goes offline during the self-test. When the self-test is ended, the printer is reset automatically.

When the self-test is executed by a command, the printer does not transmit the offline information even if the ASB is enabled.

D347 instruction manual

3) While the platen is unloaded(in standby)

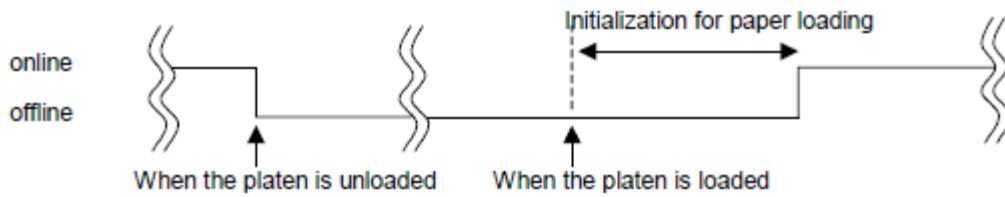

If the platen is unloaded in the printer's standby state, the printer goes offline (this is not an error). If the platen is loaded again, the printer comes online. If ASB is enabled, the printer transmits each status item each time when an event occurs.

When the printer detects a status change with the sensors, even if the printer is offline, the printer transmits the ASB.

If the sensor's status changes while paper loading is initialized, the printer transmits the offline information with the cause unknown. (if offline is not caused by an error or a paper-end).

If the offline occurs as a result of a paper near-end, wait until the printer processes a change in status or the printer comes online.

4) While the platen is unloaded(during printing)

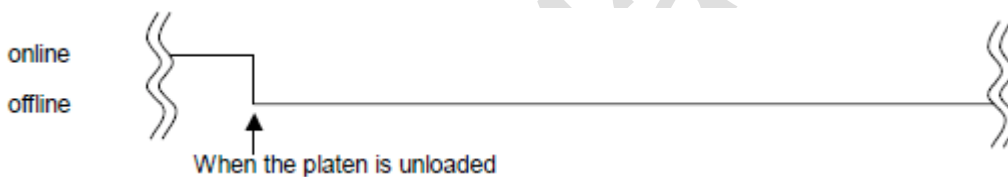

If the platen is unloaded during printing, the printer goes offline causing an error. The printer does not recover from offline only by loading the platen. Transmission of the error recovery command (DLE ENQ) or resetting is also required.

5) When paper is fed with the paper FEED button



The printer is offline when the paper is fed with the paper FEED button. The printer comes online after the current paper feeding is ended by releasing the paper FEED button.

If ASB (Auto Status Back) is enabled, the printer transmits each status item each time an event occurs.

When the printer detects a status change with the sensors, even if the printer is offline, the printer transmits the ASB.

6) When a paper-end is detected:

D347 instruction manual

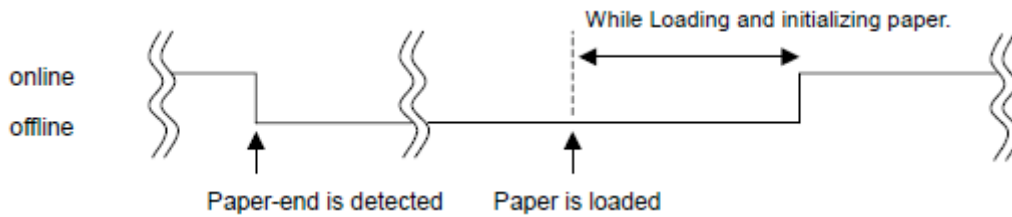

If a paper-end is detected, the printer goes offline causing printing to stop (this is not an error).

The printer recovers to online when the printer is ready to receive data, if the paper loading initialization is finished after the paper is loaded.

If ASB (Auto Status Back) is enabled, the printer transmits each status item each time an event occurs. When the printer detects a status change with the sensors, even if the printer is offline, the printer transmits the ASB.

If a status change is detected by the sensors during paper loading initialization, the printer may go offline without identifying the cause. If this occurs, wait until the status changes or until the printer goes online.

7) When an automatically recoverable error occurs:

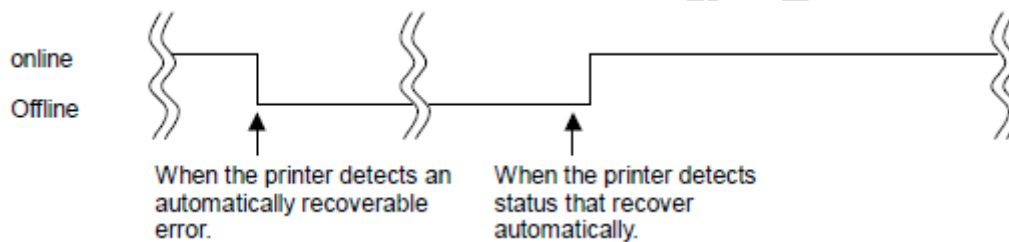

When the printer detects an automatically recoverable error, the printer goes offline.

If the printer detects status that can recover automatically, the printer recovers to online automatically. If ASB is enabled, the printer transmits the ASB when the error occurs. After that, the printer does not transmit ASB again until the printer recovers to online. In this product, a head high temperature error is one of the automatically recoverable errors.

8) When a possibly recoverable error occurs:

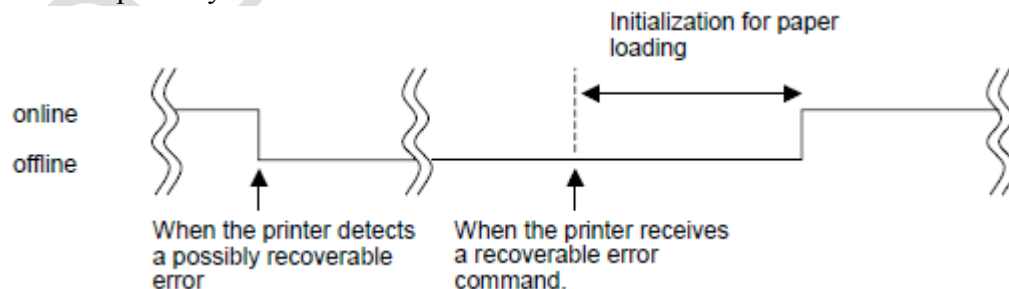

When the printer detects a possibly recoverable error, the printer goes offline.

When the printer is in the state that can possibly recover to online, the printer recovers to online by a recoverable error command or resetting the printer. (For the RESET timing, refer to 1) in this section.

If ASB is enabled, the printer transmits the ASB when the error occurs. After then the printer does not transmit the ASB again until the printer recovers to

online.

In this product, an autocutter error is one of the possibly recoverable errors.

9) When an unrecoverable error occurs:

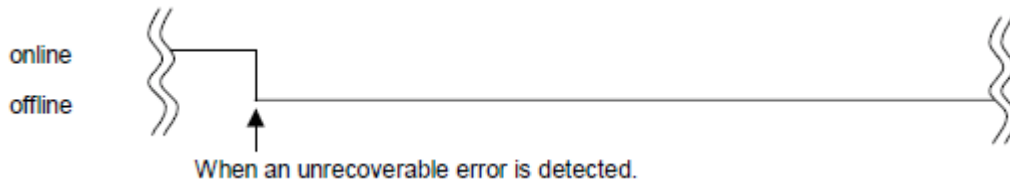

When the printer detects an unrecoverable error, the printer goes offline. The only way to recover from an unrecoverable error is to reset or turn the power off and on again. (If a malfunction causes the error, the printer won't recover until the printer is fixed.) (For the RESET timing, refer to 1) in this section.)

If ASB is enabled, the printer transmits the ASB when an error occurs. After this, the printer does not transmit the ASB again until the printer recovers to online.

In this product, a high-voltage error is one of the unrecoverable errors.

However, when a fatal error, such as a CPU execution error or a memory error, is detected, the printer won't transmit the ASB.

10) When the printer goes offline temporarily without any specified cause:

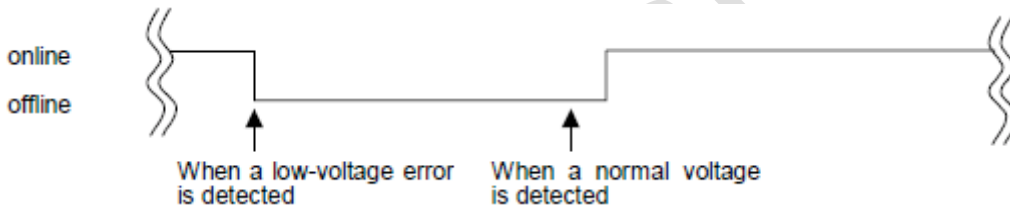

If the printer detects a low voltage temporarily while printing, the printer stops printing and goes offline without identifying the cause.

After the printer detects a normal level of the voltage, the printer comes back online and starts printing automatically. If the printer detects a low voltage again, the printer sends the low-voltage error status (unrecoverable error).

If the printer goes offline without any identified cause (for an offline not caused by an error or paper-end), when monitoring the printer's status, it is recommended not to decide the printer status until the printer recovers to online or the printer goes offline with the cause identified (for an offline caused by an error or paper-end).