

---

**Technical Manual**

**ELECTRONIC COIN SELECTOR**

**EMP 8x0.00 v5,**

**EMP 8x0.04 v5**

**and EMP 8x0.13 v5**

**- Version 1.51 -**

## **Safety Precautions**

You are advised to observe the safety information during operation, maintenance and repairing of electronic coin selectors of the EMP 800 series. Failure to do so may result in warranty and other claims being excluded.

Whilst every care has been taken in the preparation of information contained in this manual, *wh Münzprüfer* will not be liable for any consequential loss or damage howsoever caused.

This manual is protected by copyright and all rights are reserved. Without prior authorisation by *wh Münzprüfer*, no part of this manual may be reproduced in any form by photocopy, microfilm or other processes nor may it be transmitted in any form usable by data processing. The rights of reproduction by lecture are also reserved.

The Company would be very grateful if any accidental inaccuracies could be pointed out to us with any other constructive criticism which might lead to a better understanding.

## Table of Contents

1	Introduction .....	5
1.1	The EMP 8x0.00 v5, 8x0.04 v5 and 8x0.13 v5 series .....	5
1.2	Technical Data.....	7
1.2.1	The EMP 8x0.00 v5, 8x0.04 v5 and 8x0.13 v5 Coin Selector Features .....	7
1.2.2	Technical Overview of the EMP 8x0.0000 v5, 8x0.04 v5 and 8x0.13 v5.....	8
2	Function of the Coin Selector .....	9
2.1	Introduction .....	9
2.2	Programming of Coins.....	11
2.2.1	Calibration .....	11
2.2.2	Cloning (Programming without Coins) .....	14
2.3	Coin Selector Output Signals .....	15
2.3.1	EMP 8x0.00 v5 Interface .....	15
2.3.2	EMP 8x0.04 v5 Interface .....	15
2.3.3	EMP 8x0.13 v5 Interface .....	15
2.3.4	Preceding coin output signal (Option /S).....	15
2.3.5	Inventory Impulse (Option /I).....	17
2.3.6	Parallel Output Connector (ST EMP) .....	18
2.4	Coin Blocking.....	18
2.4.1	General Blocking .....	18
2.4.2	Individual Coin Blocking via DIP switches.....	19
2.4.3	Individual Coin Blocking via the Parallel Output Lines (/O Option).....	19
2.5	Coin Values .....	19
2.6	Slave Channels .....	21
2.7	Control for External Sorting Flaps .....	22
2.7.1	Option /X.....	22
2.7.2	Control of sorting flaps via coin output 5 and 6.....	22
2.7.3	Hold Time .....	22
2.7.4	Main Cash Box .....	23
2.8	Coin Return .....	23
2.9	Battery Operation .....	23
2.9.1	Option /B.....	23
2.9.2	Option /C .....	23
2.10	Safety Features .....	24
2.10.1	Coin on a String (Strimming).....	24
2.10.2	Coin Jam .....	24
2.10.3	Additional External Strimming Detection (Option /Z) .....	25
2.10.4	Lead Detection (Option /L) .....	25
2.11	Further Options.....	26
2.11.1	Power Supply Connections Reversed (Option /A) .....	26
2.11.2	Large Coin Funnel (Option /F) .....	26
3	Serial Interface.....	26
3.1	Interface Connector .....	26
3.2	SCI Interface.....	27
3.3	Multi Drop Bus (MDB).....	30
3.3.1	Protocol Specifications .....	30
3.3.2	Conventions.....	30
3.3.3	Basic Commands .....	31
3.3.4	Multi Drop Bus and Battery Operation .....	33
3.4	cctalk interface.....	35
3.4.1	Command overview.....	35
3.4.2	Assigning MDB error codes to cctalk error codes.....	37
3.4.3	cctalk adjustments using wheasy 3.....	38

4	The Label .....	38
5	Maintenance .....	40
6	Connecting Diagrams .....	41
7	EG Conformation Declaration.....	42

## 1 Introduction

### 1.1 The EMP 8x0.00 v5, 8x0.04 v5 and 8x0.13 v5 series

The electronic coin selectors EMP 8x0.00 v5, EMP 8x0.04 v5 and EMP 8x0.13 v5 are available in the following versions:

with front plate:

Standard front plate	(F 800)	<b>EMP 800.xx v5</b>
Mini front plate	(F 810)	<b>EMP 890.xx v5</b>
Stainless steel front plate	(F 801)	<b>EMP 850.xx v5</b>

for chassis / channel mounting:

reject down and to the front	<b>EMP 820.xx v5</b>
reject down and to the rear	<b>EMP 830.xx v5</b>
reject laterally	<b>EMP 840.xx v5</b>
full access opening, reject to the front	<b>EMP 860.xx v5</b>
full access opening, reject to the rear	<b>EMP 870.xx v5</b>
full access opening, reject laterally	<b>EMP 880.xx v5</b>

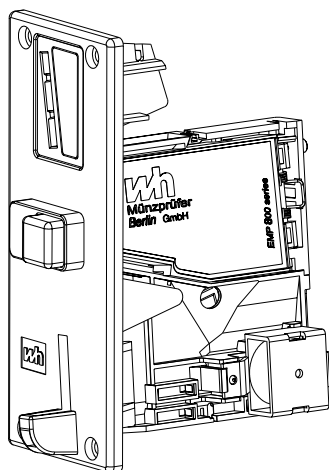

EMP 800.xx v5

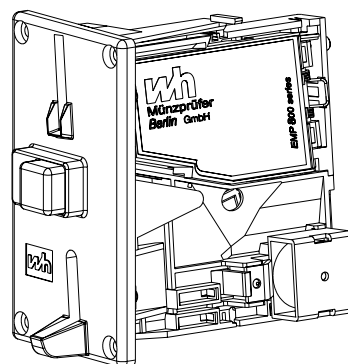

EMP 890.xx v5

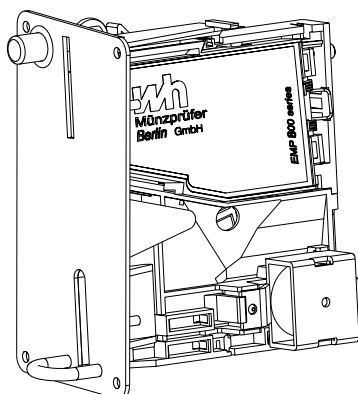

EMP 850.xx v5

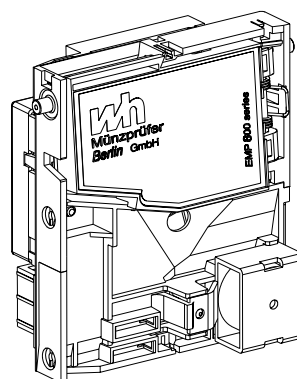

EMP 820.xx v5

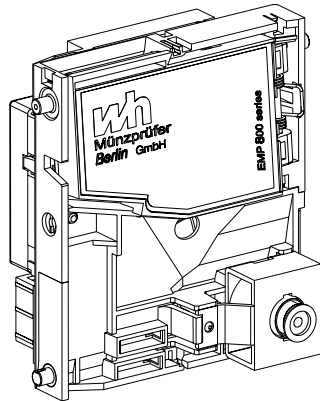

EMP 830.xx v5

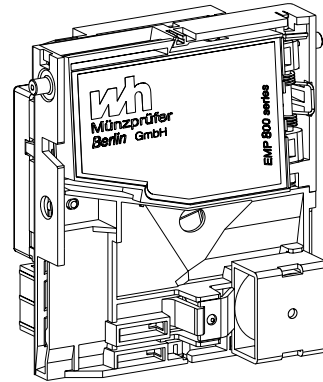

EMP 840.xx v5

☞ The second digit of the model number indicates the mechanical version and the two digits after the decimal point identify the electronic interface.

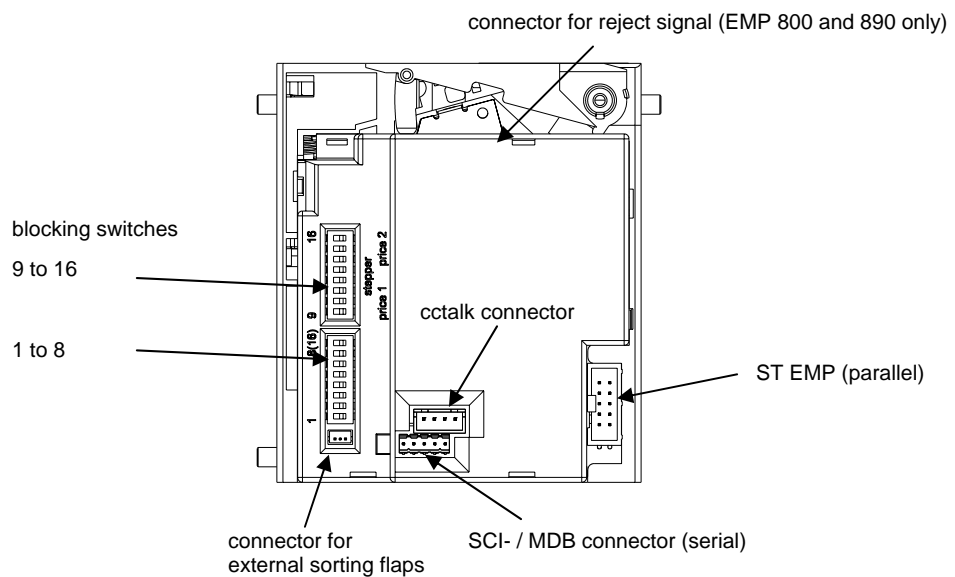

## 1.2 Technical Data

### 1.2.1 The EMP 8x0.00 v5, 8x0.04 v5 and 8x0.13 v5 Coin Selector Features

The EMP 8x0.xx v5 is a 32 channel, 6-output line coin selector. Any coin may be assigned to any parallel output channel and the length of the output pulse signal may be set from 1 ms to 65 seconds. Only 5 output channels will be available if one of the output lines is used for an inventory impulse.

The EMP 8x0.00 v5 coin channel can only be programmed to one parallel output line.

Programming output pulse signals to a combination of output lines of the EMP 8x0.04 v5 is achieved through binary coding.

The EMP 8x0.13 v5 coin selector interface supports the serial multi drop bus Protocol (mdb) and the cctalk interface. In all other respects this coin selector functions in the same manner as the EMP 8x0.00 v5 and EMP 8x0.04 v5.

The 32 coin channels are subdivided into 16 master and 16 slave channels. The slave channels can be freely assigned to the 16 master channels. However, each slave channel always has the same coin value, output line and sorting value as the assigned master channel. The slave channels are used to adjust to minting variations or for fine adjustments in the variation of coin acceptance parameters.

The EMP 800 v5 has been designed with the ability to direct external coin sorting flaps (Option /X). Three additional output lines can be used to sort a coin to a maximum of 8 different sorting flaps. Each of the 16 master channels can be assigned to one of the 8 external sorting shafts. For sorting of coins the 3-way sorter SRT 800, SRT 810 or SRT 820 are available (see Technical Manual SRT 800). With sorter SRT 810 external sorting flaps can be controlled via coin output lines 5 and 6.

The coin selector is equipped with safety functions including detection of “coin-on-a-thread” (strimming) or “coin jamming”. It has also a coin tracing system as a security provision against manipulation. Any coin jamming or drawing back of a coin-on-a-thread would cause an alarm signal to be emitted via the serial interfaces. The parallel interface may also be configured to signal alarms. The alarm signal pulses are at least 200 ms long with the parallel interface so that they can be differentiated from the coin pulse signals, normally 50 ms or 100 ms. The coin selector monitors each coin for a proper trajectory through the coin path. Deflections that suggest an attempt at manipulation are dealt with. An early detection of such an occurrence will cause the coin to be rejected. Additionally, no credit is given for a coin detected, but too late for rejection.

Enhanced safety features have been integrated into the EMP 800 product generation, v5. Depending on the programming of the selector it is also possible to block the coin acceptance for a maximum of 255 seconds automatically after a manipulation has been detected.

The EMP 800 v5 series can be programmed through the serial interface. The PC software *wheasy 3* or Palm OS® Software *whpocket 3* is available for these procedures.



wh Münzprüfer maintains a policy of continuous research and development and unconditionally reserves the right to technically modify the EMP 800 v5 series coin selector and the *wheasy 3* or *whpocket 3* software at any time.

## 1.2.2 Technical Overview of the EMP 8x0.0000 v5, 8x0.04 v5 and 8x0.13 v5

coin acceptance	32 coin channels, 16 master and 16 slave channels
coin blocking	Complete blocking via the machine controller. In addition, any individual coin, or group of coins can also be blocked through DIP switches. The 16 switches can be freely assigned to each of the 32 coin channels. Each channel can be assigned two switches.
output signals	Six open collector output lines are available. Each output line can be freely assigned to any of the 16 master coin channels through programming.  coin output lines 1 to 4: 50 volts / 100 mA coin output lines 5 to 6: 45 volts / 500 mA
output pulse length	1ms to 65 seconds, programmable
coin return	The coin selector gives an active LOW signal on the coin reject line when the coin return button is pressed.
supply voltage	8 V to 18 volts DC
supply current	60 mA maximum at standby, during coin acceptance briefly 350 mA. The standby current is 5 µA for battery operation.
temperature range	+10°C to +70 °C
humidity classification	according to DIN 40040: F
max. coin sizes	diameter: 31.5 mm thickness: 3.2 mm
dimensions	(without front plate) height: 104 mm width: 53 mm depth: 93,5 mm

### Options

/A	power supply connections are reversed, 7 coin output lines, no coin reject signal
/B	battery operation (standard)
/C	battery operation with inductive sensor
/E	extended temperature and humidity range -20°C to +70°C, humidity classification E/D:
/F	large coin funnel
/I	inventory impulse
/L	lead detection
/N	coin output signals inverted
/O	individual coin blocking via parallel lines
/P	no coin reject signal
/R	additional light barrier to observe coin return path
/S	preceding coin output signal
/T	teach mode (2 coin channels activated)
/X	control for external sorting flaps
/Z	additional external strimming detection



## 2 Function of the Coin Selector

### 2.1 Introduction

This chapter gives directions for preparing the EMP 800 v5 for programming. Please conform to all safety precautions before making changes to the unit.

Please note that all setting / programming of our electronic coin selectors may be carried out at the factory or by any authorised "wh Münzprüfer Service Centre."



Coin operated machines, as well as coin selectors are dangerous electrical devices. Always follow proper safety procedures when working with electrical devices. Please turn the power off before making or removing connections or otherwise performing work on the unit.

wh Münzprüfer v5 coin selectors can only be programmed with *wheasy* software version 3.00 onwards or *whpocket* 3 version 3.00 onwards.

This manual assumes that the *wheasy 3* programming manual and the programming software are available and that the operator is familiar with them. References here to *wheasy 3* software, are only made relative to its specific application to the particular coin selector and its functions.

To power up the EMP 800 v5 and the associated PC interface, we strongly recommend our N 780 power supply for this purpose. The power supply must be set to the 12 V position for programming and testing the EMP 800 v5. The coin selector is connected to the dongle (interface converter) with the cable provided with the software to the N 780 power supply. The dongle is connected to an available COM port. See figure 1.

As shown in figure 2, the coin selector may also be programmed whilst in situ and powered by the vending machine. This procedure requires the use of the cable K818/1800, which is not supplied with the standard *wheasy* kit.

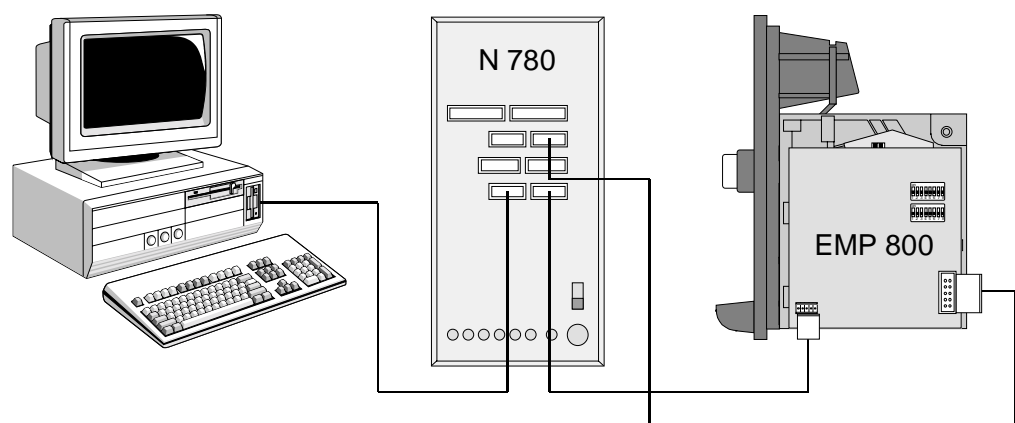

Figure 1 Connection of the coin selector with the N 780 and the PC

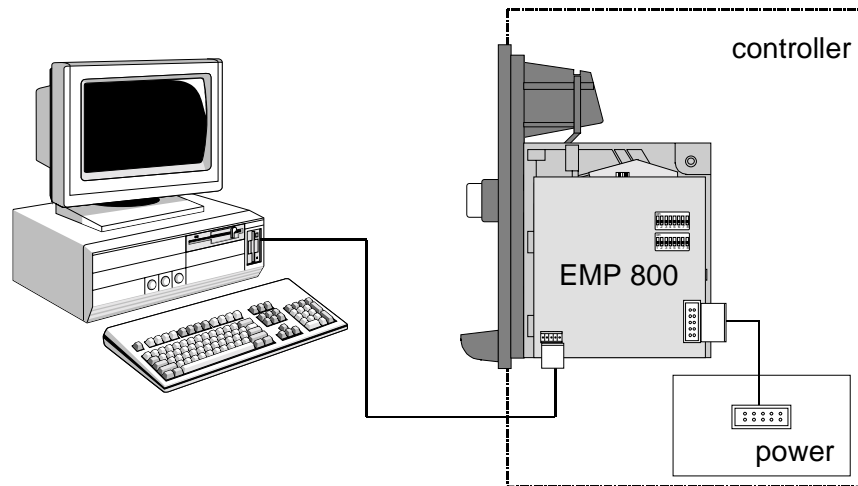

Figure 2 Connection between a coin operated machine (controller), an installed coin selector and a PC



Every coin selector is fully tested and configured at the factory and is supplied ready for installation. Please store the factory settings on the hard disk before making changes. The settings could be stored with a file name incorporating the serial number. The coin selector must be “read out” first and this procedure is explained in the *wheasy 3* manual.

Please also note the information on the coin selector label.

It is important that the coin selector be located in an upright stance when programming. Similarly, the bottom surface of the coin selector needs to be horizontal. This can often be achieved by mounting the coin selector in the same manner that it is mounted in the vending machine. Alternatively, wh Münzprüfer can provide you with a purpose designed stand T 800.

The following sections detail each *wheasy 3* related function of the coin selector. Each function has its own chapter as listed in the table of contents in this manual.

## 2.2 Programming of Coins

There are a variety of ways in which the coin acceptance of the EMP 800 v5 may be programmed.

The coin selector can “learn” new coin parameters, including individual tolerance requirements, with the help of the Calibration Function. Calibration is carried out either using the PC based *wheasy 3* software or directly in the vending machine using the Teach mode Function (see On site programming).

Yet another alternative would be to transfer a previously prepared complete coin parameter data set from the PC to the coin selector. This is commonly referred to as the Cloning Function. This method is far less involved than calibration because it dispenses with the time consuming task of inserting coins. A pre-requisite however is that an approved and appropriate coin parameter data set is available. These may be acquired via the internet from wh Münzprüfer.

The *wheasy 3* cloning function also allows the transfer of a data set from a factory set coin selector to any electronic coin selector in the same series. In this way identical programming may be duplicated for all units, as required, especially for new currencies.

### 2.2.1 Calibration

#### 2.2.1.1 Calibration Using wheasy 3

Under the Edit pull down menu is the function “Calibration”. Pressing the <F4> key can also directly access this window. This will bring up the following window:

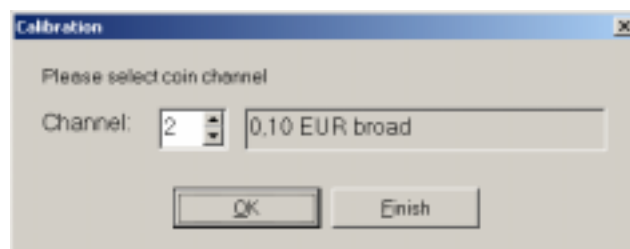

Figure 3 Window for selecting the coin channel to be calibrated.

Next, a coin channel to be calibrated is selected. The coin value and currency code for the selected channel is displayed provided that it has been written to the file as being programmed to that channel. This is shown next to the channel number.



The coin description shown is taken from the loaded file for the particular channel. Specifically, the correct description is shown only if the correct file for the coin selector has also been loaded.

The calibration window is displayed only after a coin channel has been selected. The calibration tolerance mode for the chosen channel is also shown, but this may be changed at any time prior to pressing OK.

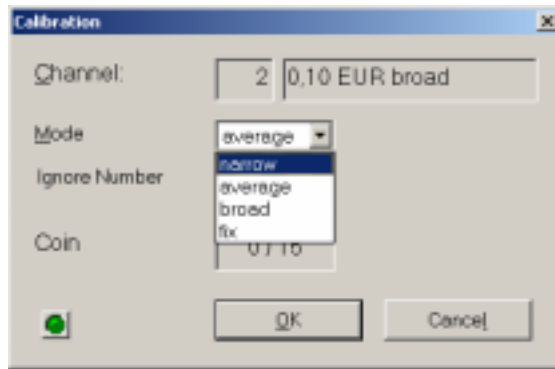

Figure 4 Calibration window for EMP 800 v5 coin selector

The calibration mode “fix” is intended for use with coins and coin channels for which preset tolerance parameters are available and calibration mode “fix” is also preset. As a general rule, “fix” provides the best results when such information is already available.

The coin tolerances are automatically adjusted to the test coin set when “narrow”, “average” or “broad” are chosen. This makes them particularly appropriate for the calibration of new coins or tokens in the absence of coin data sets.

Each of the calibration ranges approximates coin acceptance as follows:

narrow	approx. 95%,
average	approx. 98%,
broad	approx. 99%.

Obviously, the actual acceptance rate in a vending application may vary from the figures above. The level of variation relates directly to just how the coin set used for calibration is typical of the coins currently in circulation.

The number of inserted coins as well as the overall number of coins required is shown in the calibration window. The total number of required coins is determined by the data file. Calibration automatically ends once the required number of coins have been inserted and the procedure may now be finished or another coin channel selected for calibration.

### 2.2.1.2 Calibration Using the Teach Mode Function (Option /T)

The coin selector can be delivered with an optional teach mode function (on site programming). The teach mode can be set up for a maximum of 14 channels at the factory. No PC is required for the teach mode, since the necessary software is built into the coin selector.

The teach mode is activated by setting the number 8 switch on the bottom row of DIP switches to “ON”. The number 7 switch of the same DIP switch block is used to set the acceptance tolerance to “broad” or “narrow”. The “ON” setting selects a narrow tolerance.

To start the calibration it is necessary to select a channel to be calibrated by setting one channel switch to “ON”. The left DIP switch in the bottom row corresponds to channel 1 and right DIP switch in the upper row corresponds to channel 16.

The coin channel must be chosen after activation of the teach mode switch 8. The advantage is that it is not necessary to set all DIP switches to “OFF” first before programming a particular channel.

Channels 7 and 8 cannot be calibrated with the teach mode because the DIP switches 7 and 8 are used to set the acceptance tolerance and to activate teach mode respectively.



Only 15 blocking switches are available on those coin selectors that have been factory set with the teach mode. The coin selector will not accept any coins while it is in the teach mode.

Figure 5 below shows the example of setting up channel 15 for calibration with narrow acceptance tolerances.

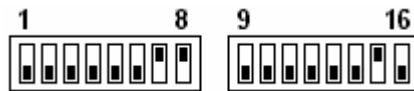

Figure 5 Example DIP switch settings for teaching channel 15 with narrow tolerances.

The following procedure is for coin selectors with activated teach mode (factory setting):

1. The coin selector is configured, so that only **coin channel 15** and **16** (i.e. coin output lines 5 and 6) may be used for teaching.
2. The teach mode is activated via **blocking switch no. 8** (ON). Additionally please insert a coin into the coin selector incorporating battery operation (EMP8x0.xx /B). The coin selector remains switched on until the teach mode will be switched off again.
3. If **blocking switch no. 7** is activated additionally (ON), teaching is effected using **narrow tolerances**
4. The **blocking switches 15** and **16** are used to teach **coin channels 15** and **16**. The switches have to be set to the OFF position when activating the teach mode, otherwise the coin selector software blocks the two channels for the teach mode.
5. If any coin blocking switches are activated (ON) for channels which are not released for the teach mode, the coin selector magnet will operate briefly three times to indicate an incorrect operation.
6. To program the coin selector with the teach mode a **minimum of 10 coins or tokens** must be inserted. When the requisite number of coins have been inserted and the teaching procedure has been completed (by setting the blocking switch no. 15 or 16 back to the OFF position), the coin selector magnet will operate briefly and once only.
7. Should the coin selector establish an **overlapping** of the newly programmed coin with a coin / token already programmed, then the coin selector magnet will operate briefly twice and no new data will be stored in the memory of the selector.
8. **Insufficient coins** being inserted will result in the magnet not operating and no new data will be stored into the memory of the selector.
9. For security reasons during teaching, the coin selector will rate all measured values of added coins as overlapping unless at least one parameter differs from any existing coin parameter tolerance. Should the programming not be

successful when using „broad“ tolerances (blocking switch no. 7 OFF), teaching could be still possible using the narrow tolerances.

- The teach mode is deactivated via **blocking switch no. 8** (OFF). When the teach mode is deactivated, all blocking switches may then be used for individual coin blocking with the exception of blocking switch no. 8.

### 2.2.2 Cloning (Programming without Coins)

Cloning is the fastest way in which to program a coin set. Using this method, coin parameter sets are transferred into the coin selector from the PC. It is also possible to transfer a coin parameter set from one coin selector to another thereby giving it nearly identical acceptance and reject rates. It does not make any difference whether the cloning data set is a *wh* original data set or whether it was copied from a coin selector and stored in the PC.

As a prerequisite to cloning, it is necessary for the coin measuring system of the originating coin selector to be the same as the measuring system of the target coin selector. *wheasy 3* automatically compares the measuring configuration of the attached coin selector with the measuring configuration of the coin selector that produced the coin parameter set. Cloning is only accomplished if the two systems are indeed the same.

Other data sets are available from *wh Münzprüfer* if *wheasy 3* does not allow cloning because of a mismatch in the measuring system characteristics.

Cloning can begin once the PC has been loaded with the cloning data set and when the coin selector has been connected. This function can be accessed by selecting “EMP cloning” from the “Data” pull down menu or directly by clicking



on the tool bar.

The following window opens up after selecting the function “EMP Cloning“:

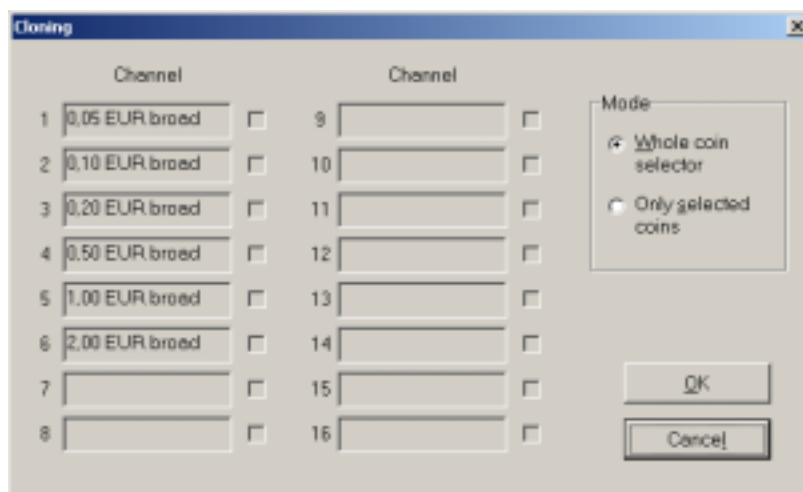

Figure 6 Window “EMP Cloning“

In certain situations it is possible to selectively clone individual channels. This can be carried out provided that the loaded data file is identical with the name of the file loaded from the coin selector. This we refer to as selective cloning.

Selective cloning is useful when the parameters for a specific coin are to be changed, or maybe a token is to be added without overwriting the fine tuning of

other coins. With selective cloning all coin channels with activated coin boxes will be cloned.

The actual cloning process takes about 15 seconds after the OK button has been pressed.

## 2.3 Coin Selector Output Signals

There are 6 open collector parallel outputs (current sink) on the EMP 800 v5 10-pin connector. They can be freely assigned in any combination to the 16 master channels. This means that (depending on the model) one coin channel can show up on multiple output lines or that one output line can be activated by multiple channels. The 16 slave channels always have the same output combination as the associated master channel.

In addition the number of output impulses for every coin can be programmed (multi pulse operation).

The coin selector signals an active LOW pulse after accepting a programmed coin or token to a particular output line or to a combination of output lines. Pulse width (in case of multi pulse operation also pulse pauses) can be programmed between 1ms and 65 ms.

For some applications it is necessary to invert the output signals, i.e. switching from LOW to HIGH instead of from HIGH to LOW. This can easily be programmed using *wheasy 3*.

This multiple configuration possibilities guaranties highest flexibility of the selectors. The *wheasy 3* manual details the assignment of output lines to specific coin channels, as well as the pulse width assignment.

### 2.3.1 EMP 8x0.00 v5 Interface

Only one output line per channel is assigned on the EMP 8x0.00 v5. Correspondingly, only 6 different coin type signals can be identified with this version. If more than 6 coin values are required the multi pulse operation can be used. For example 2 pulses can be generated for 20 Cent on 10 Cent output line.

### 2.3.2 EMP 8x0.04 v5 Interface

Multiple output lines can be assigned with the EMP 8x0.04 v5 version and each coin channel can have a binary coded output. Multi pulse can also be generated with binary coded output signals.



The coin selector will not give any output pulse if a coin channel is assigned the value of 0. The coin, will however, be accepted.

### 2.3.3 EMP 8x0.13 v5 Interface

The EMP 8x0.13 v5 supports the serial multi drop bus protocol (mdb) and the cctalk protocol. Chapter 3 has more information about this interface.

### 2.3.4 Preceding coin output signal (Option /S)

The selector can be programmed at the factory to give an assigned preceding coin output signal. This output pulse is given as soon as the coin has been identified.

The signal is, however, of a very short duration relative to the normal acceptance output signal (credit pulse).

This preceding coin output signal pulses before the coin selector magnet is activated. The signal has a maximum width of 10 ms if the coin selector is blocked (from accepting coins) via the general blocking input. The coin selector will only accept the coin if the general blocking signal is changed to “accept coin” during this 10 ms interval. The coin selector will release the normal coin acceptance signal (credit pulse) once the coin has passed the coin light barrier.

The following two diagrams illustrate the function and timing of the preceding signal.

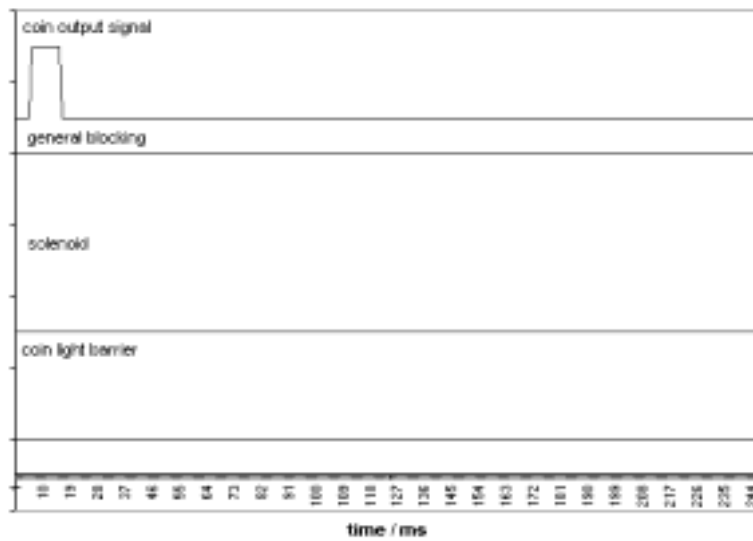

Figure 7 Preceding signal after the coin has been identified. The main blocking input line does not go high.

Figure. 7 illustrates that the coin is rejected because the general blocking input line was not changed after the coin was identified. The preceding coin output signal pulse has a maximum duration of 10 ms.

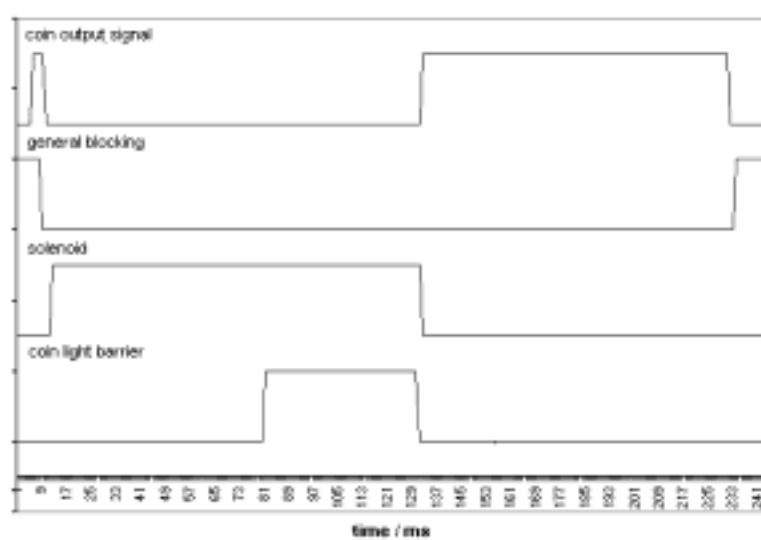

Figure 8 Preceding signal after coin identification, followed by the acceptance of the coin.



Figure 8 shows the acceptance of the coin after it has been identified. The sequence of events is as follows:

- The preceding signal starts on the assigned output line after the coin has been identified.
- The machine controller removes the general blocking signal after 3 ms. Almost immediately, the coin selector ends the preceding signal and energizes the acceptance magnet.
- Approximately 60 ms later the coin interrupts the light barrier.
- Approximately 50 ms after this the coin has passed the light barrier and the coin selector gives the normal output impulse (50 ms in this example)
- The machine controller re-instates the general blocking line no later than on completion of the credit pulse.

### 2.3.4.1 Why use the preceding coin output signal ?

It is a very useful facility should there be a need to block specific coins or in applications where the coin selector has to activate an additional sorting mechanism prior to the coin leaving the coin selector.

External single coin blocking activated by the machine controller was not possible with previous coin selectors, but this may now be carried out very simply with general blocking. When coins are to be rejected by the machine, the machine controller simply does not remove the general blocking following receipt of the preceding coin output signal. Those coins are rejected and no credit is given. For coins that are to be accepted, the general blocking is removed by the machine controller and the normal output signal (credit pulse) is released by the coin selector.

Additionally the machine controller can activate a post-coin selector sorting mechanism even before the coin has left the coin selector (chapter 2.7 Option /X).



Preceding pulses can also be used in combination with binary coded output signals. It is not advisable to use it in combination with multi pulse operation

### 2.3.5 Inventory Impulse (Option /I)

The EMP 800 v5 may be programmed to release an inventory or credit impulse. This inventory impulse is intended for the counting and logging of accepted coins. The impulse length and impulse pause are individually programmable in the range of 1 to 255 ms. Inventory impulses can be assigned to any output line. The factory standard is an impulse duty factor of 50 ms/50 ms released on output line 6

*wheasy 3* can be used to activate inventory impulses. The checkbox can be found under "Configuration", "B-Values" as part of the "Receipt" dialog box. The value is set under "Edit", "Coin Values" in the field "S.Value".



As a rule the value of the inventory impulse corresponds with the value of the smallest programmed coin. The EMP 800 v5 allows programming of higher values. Inserted coins are added up and the inventory impulse is given after the S.Value has been reached.

### 2.3.6 Parallel Output Connector (ST EMP)

The parallel output connector is a 10-pin, dual row .1-inch center jack as specified by DIN 41651. The connector has the following pin out:

Pin No.	Connection
1	GND
2	Power supply (UB)
3	coin output 5
4	coin output 6 or inventory impulse
5	Reject (active low)
6	general blocking (input)
7	coin output 1
8	coin output 2
9	coin output 3
10	coin output 4

## 2.4 Coin Blocking

Coin blocking may be accomplished in various ways. One possibility is the general blocking input line, which will block the coin selector from accepting all coins. Secondly, it is possible to block coins or groups of coins individually through 16 DIP blocking switches on the coin selector. The DIP blocking switches are accessible through a recess in the coin selector cover.

The (/O) factory option can be specified for the individual blocking of up to 6 different channels or groups of channels via the six parallel output lines.

### 2.4.1 General Blocking

General blocking is activated through pin 6 of the 10-pin connector on the coin selector. The general blocking signal is a standard active “high” to block. Unless programmed otherwise, an open (unconnected) input will allow coins to be accepted. Any voltage between 5 and 24 V DC is considered a high signal.

The signal polarity of the blocking line is programmable. The programming can be carried out using *wheasy 3* under the menu selection “Configuration”. Select “B-Values”, select the register tab “Mode.” This tab, among other things, has a check box for “Main blocking with 0” and “Main blocking with an open input.” The following table shows all combinations of the above two options.

selected check box		general blocking input		
general blocking with “0”	general blocking with an open input	HIGH	LOW	TRISTATE
		X		
	X	X		X
X			X	
X	X		X	X

Table 1 The function of general blocking in relationship to the programmed mode of the coin selector.

In certain circumstances, the general blocking signal can also be used to block individual coins (chapter 2.3.4 preceding coin output signal – Option /S).

## 2.4.2 Individual Coin Blocking via DIP switches

The coin selector has 16 DIP switches for individual coin blocking. Blocking is not active, that is, the coin will be accepted when the switch is in the “OFF” position. A coin will be rejected when the switch is “ON”.

The 16 switches can be freely assigned to the 32 coin channels. Each coin channel can be associated with two switches. This configuration makes it possible to block individual coins or, if multiple currencies are programmed, it is possible to block a whole currency with one switch. For example 12 individual coins can be assigned to the first 12 switches. Then switch 13 to 16 can be used to block whole currencies. This optimal use of the switches allows the easy selection of one currency or even multiple currencies at the same time.

The following figure illustrates the assignment of blocking switches and also the numeric identity of each switch.



The lower switch position is the “Off” position. The upper switch position denotes “ON”. In this example all coins assigned to switch 7, 8 and 15 are blocked.

Figure 9 Blocking assignment.

The programming of the blocking switches is done with *wheasy 3* and is explained in the *wheasy 3* technical manual.

## 2.4.3 Individual Coin Blocking via the Parallel Output Lines (/O Option)

The /O option makes it possible to block up to 6 coins or coin groups through the 6 parallel (open collector) output lines. This blocking is accomplished when the machine controller pulls the associated output line LOW.

Note that this blocking option has the same effect as the blocking switches 9 through 14 to the micro processor.



This option must be specified at the time that the coin selector is ordered. The coin selector cannot be retrofitted with this option.

## 2.5 Coin Values

Each coin programmed into the coin selector is also given a coin value. This value may be used for the inventory impulses and it is also used as part of the MDB status request. Most importantly programming the coin values display a check on what is already programmed in coin selector including channel assignments.

16 different coin values can be programmed into the master channels. The slave channels always have the same coin value as the master channel.

The “Coin Values” selection is available under the “Edit” pull down menu. This window can be used to set and edit the coin values for each channel. Please note that only part of the information in this window is transferred to the coin selector. The rest is just stored as part of the data on the PC and is used to better describe and understand each channel while working with *wheasy 3*.

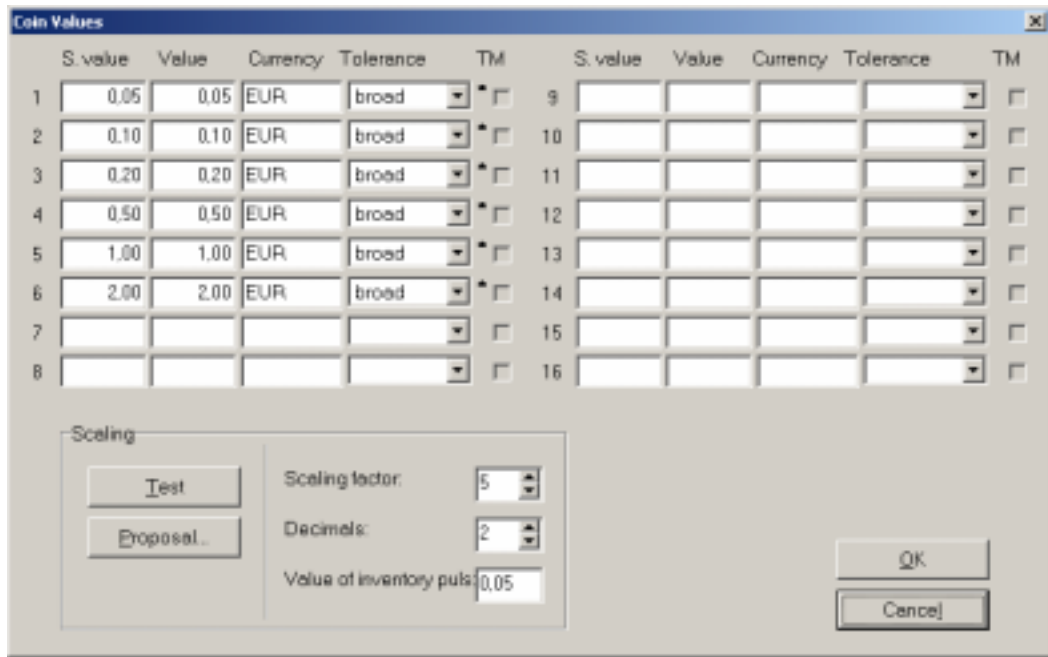

Figure 10 Window for “Coin Values”

The individual fields are defined as follows:

- S.Value (Calculated Coin value)  
The calculated coin value is stored in the coin selector. This value uses the machine controller for the determination of credit and the selector for calculating the number of inventory pulses.
- Value (Actual coin value)  
This “value” is not stored in the coin selector. In certain situations it may be necessary to give a coin an S.value other than its face value. For example, a rebate value may be assigned to a particularly valuable coin. In this case, the “value” is displayed for clarity when working with *wheasy 3*.
- Currency  
The currency description is not stored in the coin selector. However, it is still important to have this description when working with *wheasy 3* because a coin selector may be programmed to accept multiple currencies.
- Tolerance  
The tolerances are stored in the coin selector. They serve to provide a better overview when working with *wheasy 3*. The desired tolerances “broad”, “narrow”, “or very narrow “ or “no indication” may be entered here.
- TM (Teach mode)  
This choice enables the coin selector mounted DIP switch teach mode function for a channel. This mode is activated when the appropriate box shows a “√”.

A star (\*) may be shown to the left of the “TM” checkbox. The star indicates that this master channel also has a slave channel associated with it (See section 2.6 slave channels).

There are some special fields at the bottom of the window, below the heading of "Scaling." These adjustable parameters have the following meaning:

- **Scaling Factor**  
This value is used in vending machines that communicate with the coin selector over the serial MDB protocol. The vending machine may read these values during a status request.
- **Decimals**  
A decimal point location is likewise transferred to the vending machine during a status request as part of the MDB protocol. This value tells the vending machine how many digits to use after the decimal point as part of the coin value.
- **Set Value**  
A set value represents one impulse when inventory pulses are generated. For those coin selectors that calculate prices and the price is set up via the binary price switches, the set value is also used as the multiplication factor.
- **Test button**  
This button is used to let *wheasy 3* test whether it is possible to create 8 bit coin values for the MDB status request with the given scaling factor and decimal location.
- **Proposal button**  
*wheasy 3* attempts to find a scaling factor and a decimal point position that works for the status request. It is not possible to find such a value if the largest coin value is more than 255 times greater than the smallest coin value. In this case an error message is shown.

## 2.6 Slave Channels

The generation v5 selectors also have 16 slave channels (Channels 17 to 32) available in addition to the so-called 16 master channels. The slave channels can have their own settings for the coin parameters and blocking switches. The slave channels may be assigned arbitrarily to any master channels. It is even possible to assign multiple slave channels (up to 16) to a master channel. The slave channel assignment can be carried out in *wheasy 3* with the "Edit" pull down and then selecting "Slave channel." This is discussed in the *wheasy 3* manual.

The slave channels share the following attributes with the associated master channel:

- **Output channel.** This means that the slave channel will always signal the same output line as the associated master channel.
- **Coin Value**
- **Sorting shaft**

An exception is possible with the EMP 8x0.13 v5 with Multi drop Bus interface under certain circumstances. Here it is possible for the slave channel number to be sent individually.

## 2.7 Control for External Sorting Flaps

The 2- or 3-way sorter SRT 800 is available for the EMP 800 v5. The coin selector can also be used in combination with many other sorter available on the market.

### 2.7.1 Option /X

The EMP 800 v5 incorporating option /X provides a control for external coin sorting flaps. The control signals of the microprocessor are transmitted via 3 additional output lines. The output lines are protected by a 330 KΩ resistor. Therefore no further circuit is necessary to drive 3 transistors for the control of 3 solenoids. 8 possible sorting shafts can be achieved by means of the various combinations.

The desired external routing can be assigned to any of the 16 master coin channels by the use of *wheasy 3*. The routing possibilities are programmed by means of the binary code using the values from 0 to 7. When zero is programmed only the solenoid of the coin selector will be activated and none of the additional output lines. The values 1 to 7 stand for the binary coded combination of the external solenoids to be activated.

The programming of external sorting solenoids is discussed in the *wheasy 3* manual in the “Sorting Shaft” chapter.

### 2.7.2 Control of sorting flaps via coin output 5 and 6

Via coin output line 5 and 6 it is also possible to control sorting flaps. The output transistors can drive a current up to 500 mA. This function can be activated by using *wheasy 3* under “configuration” – “B-Value” – menu “variants” click checkbox “additional sorting flaps via coin output lines”.

The sorting signal can be selected via “edit” – “sorting shafts” for each coin channel. The following table shows an overview on the different sorting possibilities.

Sorting shaft	Output line 5	Output line 6
0	0	0
1	1	0
2	0	1
3	1	1

The timing for the control of the sorting flaps can be set independently to the timing of the coin output signals.

For the coin output signals output lines 1 to 4 are available with this version. The sorter version to be used for this application is the SRT 820.

### 2.7.3 Hold Time

The maximum hold time (pulse width) for the external sorting mechanism can be programmed at the factory to match the requirements of the mechanism. The maximum hold time is 510 ms, with the start time measured from the time that the

coin exits the coin selector. The coin selector will not accept any additional coins during this hold time unless they are of the same type as those then being sorted.

Optionally, the hold time can be shortened by programming at the factory. The hold time will be cancelled by briefly activating the general blocking line. If the external sorting mechanism can track the coin trajectory, the machine controller can signal the coin selector to accept another coin sooner once it has been determined that a coin has cleared the sorting mechanism.

#### 2.7.4 Main Cash Box

The EMP 8x0.13 v5 can be set up to direct coins to a main cash box when connected to the vending machine through the MDB or cctalk protocol. The main cash box is then specified for all accepted coins.

The programming of the main cash box is discussed in the *wheasy 3* manual in the "Edit" chapter, under the sub-heading "Sorting Shafts."

### 2.8 Coin Return

The coin selector EMP 800 v5 has a feature which will identify and give credit for a coin, and then return it. This feature can be used, for example with test tokens. It can also be used where certain persons, for example employees, are to receive benefits without cost (e.g. car parking).

The setting of this function is also discussed in the *wheasy 3* manual in the "Edit" chapter, under the sub-heading "Sorting Shafts."

### 2.9 Battery Operation

#### 2.9.1 Option /B

Battery operated selectors with option /B use a piezo-electric element for the wake up function. A coin selector with the battery operation option will not use any current ( $< 5 \mu\text{A}$ ) while in the stand by mode. The coin selector only turns itself on when a coin is inserted. The coin selector turns itself back off after the coin has been measured, passed the acceptance light barrier and an output impulse has been released. The coin selector is on for a maximum of 800 ms while it attempts to recognize a coin.

The activation of battery operation can be set with *wheasy 3* with the "Configuration" pull down menu. Select "B-values" and then "Mode" .



Do not enable battery operation unless the coin selector has been manufactured with this necessary hardware. The coin selector label will specify the /B option if this is the case.

The EMP 8x0.13 v5 has some additional special requirements for battery operation. These are discussed in chapter 3.3.4.

#### 2.9.2 Option /C

An inductive switch is used for the wake up function for battery operated units with option /C. During standby the current consumption is less than  $10 \mu\text{A}$ . This option should be considered if there might be vibrations that could wake up the coin selector (for example table footballs). All other functions are identical to the coin selector with option /B.

---

## 2.10 Safety Features

### 2.10.1 Coin on a String (Strimming)

The EMP 800 v5 is equipped with multiple safety functions to prevent almost every coin-on-a-string manipulation.

As an additional security the coin selector can signal attempts of manipulation to the machine controller. It is also possible to block coin acceptance for a programmed time in order to make further attempts of manipulation more difficult.

Even if the coin selector is in standby mode, the light barriers are still live (continuous operation only). If the light barrier detects a coin in the acceptance channel which has not previously passed the measuring system in the correct way, the coin selector will assume that this coin, for which a receipt has been transmitted, is being pulled back on a thread. Via the parallel interface, the coin selector can give a message for coin-on-a-thread-detection to the machine. The customer can choose any of the coin output channels or a combination of channels through which the coin-on-a-thread detection is to be signalled. This can be programmed by the factory. The information is emitted by a minimum impulse width of 200 ms. The machine is able to distinguish between coin-on-a-thread detection and a normal receipt signal, as it can recognise the different width and (or) identify a combination of simultaneously arranged coin output lines.

The message "coin-on-a-thread" is also transmitted via serial SCI, MDB and cctalk interface (see chapter 3.2 and 3.3).

If a coin is still identified in the light barrier after 200 ms have passed, the information will be repeated. During that time, no coin can be accepted.

### 2.10.2 Coin Jam

If the measuring system identifies a coin, but measuring is concluded via "timeout" instead of the correct measuring procedure (coin leaves coin selector passing the receipt light barrier or the return), this will be interpreted as "coin jamming".

Via the parallel interface, the coin selector can give a signal for coin jamming to the machine. The customer can choose any of the coin output channels or a combination of channels through which coin jamming will be signalled. This can be programmed by the factory. The information is emitted by a minimum impulse width of 200 ms. The machine is able to distinguish between coin jamming and a normal receipt signal, as it can recognise the different width and (or) identify a combination of simultaneously arranged coin output lines.

The message "coin jam" is also transmitted via serial SCI, MDB and cctalk interface (see chapter 3.2 and 3.3). The serial interface also allows the position of the coin jam to be specified:

The following coin jam signals are possible:

- Coin jam 1 (in the measurement system)
- Coin jam 2 (between measurement system and reject light barrier), only option /R
- Coin jam 3 (between measurement system and acceptance light barrier)
- Coin jam 4 (in the acceptance light barrier)
- Coin jam 5 (not possible with the EMP 800 v5)
- Coin jam 6 (in the reject light barrier) only option /R



If a coin is still identified in the light barrier after 200 ms have passed, the message will be repeated. During this time, coin acceptance is blocked.

### **2.10.3 Additional External Strimming Detection (Option /Z)**

For certain applications an additional strimming detector to avoid manipulation is recommended, especially when working with an escrow.

The sensor also allows a coin on a string detection in units with battery operation. In this case a 14-pole plug is used instead of a 10-pole EMP plug.

The reed contact of this sensor is closed if a coin on a string is detected. The contacts of the reed switch are signalled via pin 11 and 12 of the 14-pin plug and can be read potential free.

As a special version the signal of the string sensor can be made available via the serial interface. With battery operated units the coin selector turns itself on if the string sensor is activated.

### **2.10.4 Lead Detection (Option /L)**

The EMP 8x0.xx v5 can be equipped with the option lead detection to detect lead counterfeits which may not be separated satisfactorily by using standard coin parameters.

#### **2.10.4.1 Additional light barrier to observe Coin Return Path (Option /R)**

A total monitoring of coins from insertion through to the point of leaving the selector is possible with this option. As an example - coin jamming in the return shaft caused through manipulation can be signalled to the machine controller. As an extra protection an anti pin system can prevent the insertion of further coins and thereby further damage to the machine.

Via the parallel interface a coin jamming signal can be given. Using the serial interface coin jamming 2 or coin jamming 6 is signalled.

 Coin selectors with option /R do not have double light barriers.

## 2.11 Further Options

### 2.11.1 Power Supply Connections Reversed (Option /A)

The polarity of the power supply inputs are reversed with this option, i.e. pin 1 of the EMP connector is UB (instead of GND) and pin 2 is GND (instead of UB). As there is no output channel being used for the reject signal, 7 output channels are now available. This version is especially designed for gaming machines on the Spanish market.

### 2.11.2 Large Coin Funnel (Option /F)

An alternative funnel can be supplied if a bigger insertion is required. Dimensions are shown in the drawings below.

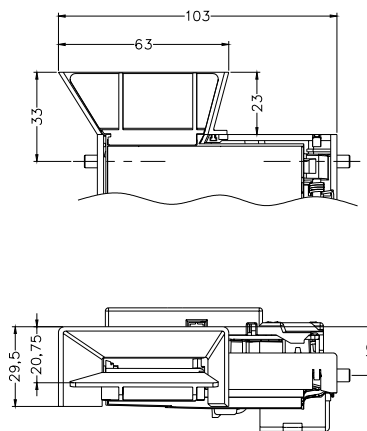

## 3 Serial Interface

The EMP 800 v5 serial interface communicates over one of three different protocols with the vending machine. The first serial protocol is the SCI (serial communication interface), in which the coin selector sends out a 5-byte data frame to the machine controller after each event. The other serial protocol is the multi drop bus protocol, which also serves as the programming interface. The third serial protocol is cctalk, which has its own connector.

All three interfaces operate at 9600-baud rate.

### 3.1 Interface Connector

An AMP (Quick 828548-5) single in line 5-pin connector is used as serial connector for the SCI and multi drop bus protocol.

PIN No.	Description
1	GND (ground)
2	UB (positive power supply, 8 to 18 volts DC)
3	CLK (clock)
4	TDO (transmit data out)
5	RDI (receive data in)

## 3.2 SCI Interface

The EMP 800 v5 communicates through a serial interface with the following specifications:

data format: 9600 Baud, 1 start bit, 1 stop bit, no parity, 8 data bits, separate send and receive lines.

high level	+ 5V	logical 0
low level	0 V	logical 1

The SCI interface of the coin selector can be programmed to operate in one of two modes:

1. The programmed coin value of the last accepted coin is sent repeatedly at a rate of 5 messages a second.
2. The programmed coin value is only sent once after the coin is accepted.

The SCI mode can be configured with the programming software *wheasy 3*. Select the "Configuration" pull down menu. Select "B-values" and then the "Credit" tab. The checkbox "Just 1x SCI" toggles sets the mode so that the data set is only set once.

In addition, it is possible to specify whether the slave channel takes on the associated master channel number, or whether it signals using its own assigned channel number. *wheasy 3* can be used to set this up. Select the "Configuration" pull down menu. Select "B-values" and then the "Credit" tab. Select the check box "Signal 32 channels".

It is also possible to set up the EMP 800 v5 so that the possible error messages are the same as those of the EMP 800 v3. This may be necessary if the EMP 800 v5 with the SCI interface is to be integrated into older systems. Using *wheasy 3*, select the "Configuration" pull down menu. Select "B-values" and then the "Mode" tab. Select the check box "SCI v3 compatible."

The EMP 800 v5 sends a 5-byte data frame with each message. The first 4 bytes each are one digit of the value of the accepted coin. The fifth byte contains information such as the channel number (with accepted coins), whether the coin return was pressed, if the channel was blocked, error messages, etc.

The data bytes have the following format:

1. Start bit
2. LSB
- ...
9. MSB
10. Stop bit

The least significant byte (LSD) of the data bytes is sent first. All other bytes follow relative to their ascending value. The details of the value of the corresponding decimal place is included (hexadecimal) in the lower nibble of the bytes. The upper nibble shows again the place.

Value of the data bytes  
(X: value between 0 and 9)

Ascending Value

FXh  
EXh  
DXh  
CXh

MSD (Most Significant Digit)

LSD (Least Significant Digit)

The EMP 800 v5 is always a master device when it is in SCI Mode. The SCI interface transfers 5 bytes with a refresh frequency of 5 Hz or after each result.

Definition of the 5th byte:

value of the 5th byte (HEX)	Meaning		
	standard	32 channel messages	SCI v3 compatible
70H ... 7FH	/	coin channel 17 ... 32 recognized	/
80H ... 8FH	coin channel 1 ... 16 recognized		
90H	coin return button pressed		
91H	reject – coin following to closely		
92H	coin jamming 1		/
93H	reject – no matching parameter set		
94H	/		reject – coin channel blocked
95H	coin jamming 2		/
96H	reject – DIP switch blocking		/
97H	coin jamming 3		coin jamming
98H	coin jamming 4		/
99H	coin jamming 6		/
9AH	reject – rim detection (not available yet)		
9BH	reject – lead detection		
9DH	coin on a thread		
9EH	reject – general blocking		
9FH	reject – coin selector busy		

**Example:**

programmed value of the accepted coin	transferred data, binary	data, hexadecimal
Chan. 1 20.00	1100 000 1101 0000 1110 0000 1111 0010 1000 0001	C0 D0 E0 F2 80
Chan 2 05.00	1100 0000 1101 0000 1110 0101 1111 0000 1000 0010	C0 D0 E5 F0 81
Chan 3 00.50	1100 0000 1101 0101 1110 0000 1111 0000 1000 0011	C0 D5 E0 F0 82
Chan 4 00.25	1100 0101 1101 0010 1110 0000 1111 0000 1000 0100	C5 D2 E0 F0 83
Chan 17 00.05	1100 0101 1101 0000 1110 0000 1111 0000 0111 0001	C5 D0 E0 F0 70

Figure 11 Data format for acceptance of coins with different coin values and different channels

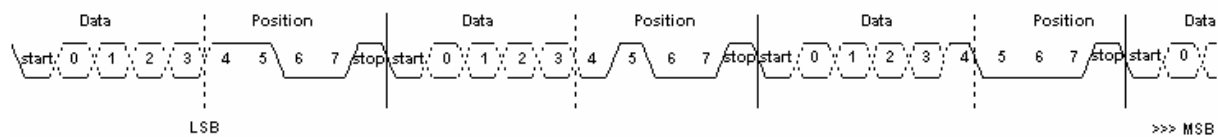

Figure 12 Timing diagram for the first 3 data bytes

### 3.3 Multi Drop Bus (MDB)

The coin selector can be set up to communicate with the machine controller using the MDB protocol. *wheasy 3* can be used to program this setting. Select "Settings", then "Operating Mode". Choose MDB. Also be sure that the "Multi Drop Bus" check box is checked under "Configuration," "B-Values" and then select the "Mode" tab.



The EMP 800 v5 has an implementation of the MDB protocol according to I.C.P. (MDB European Version). The still free available address 15 h was chosen in order to avoid conflicts with other MDB devices. The command set and the bus timing correspond to I.C.P. standard. Additionally a MDB adapter is available if the hardware specification of the interface is also requested.

#### 3.3.1 Protocol Specifications

- **Data format:**
  - 1 start bit
  - 8 data bits
  - 1 mode bit
  - 1 stop bit

- **Mode bit:        VMC to EMP**

The mode bit distinguishes ADDRESS bytes and DATA bytes. ADDRESS bytes are read by all peripheral devices and DATA bytes are only read by active peripheral devices. An active peripheral device is defined as a device that has successfully established a contact with the master (VMC).

The mode bit is set (logically 1) in order to mark an ADDRESS byte. When the mode bit is not set (logically 0) it marks a data byte.

- **Mode bit:        EMP to VMC**

The mode bit is set with the last byte when the slave (EMP) is transmitting data to the master (VMC). Consequently, the slave (EMP) always sets the mode bit together with the check sum or with ACK.

- **Check sum**

The last byte of every data transfer from the VMC to the EMP is always the check sum.

#### 3.3.2 Conventions

Using the Multi drop Bus all commands and answers must be answered within 5 milliseconds or acknowledged respectively!

The coin selector answers every command and every polling within 5 milliseconds. If the coin selector is busy and therefore can not answer within the 5 milliseconds the selectors loses the command. The VMC (Vending Machine Controller) must handle this as a NACK (FFh).

All answers from the coin selector to a poll command must be acknowledged through the VMC within 5 milliseconds with ACK (00h). If no acknowledgement has been received within 5 milliseconds the coin selector handles this as a NACK and transmits the same answer on the next poll command again.

### 3.3.3 Basic Commands

Command	Code	Data
RESET	78h	-

The acceptance of coins is blocked. The response to the next poll is 07h (Reset).

Command	Code	Data from the coin selector
STATUS	79h	30 byte Z1 to Z30

Z1	[reserved]
Z2 - Z3	country code
Z4	scaling factor
Z5	decimal place
Z6	number of sorting shafts (upper nibble) shaft of main cash box (lower nibble)
Z7 - Z14	channel – shaft assignment in one nibble the number of a coin channel beginning with the shaft number of type 0; in the upper nibble beginning with Z7
Z15 - Z30	values of coins, beginning with type 0 in Z15

Command	Code	Modifier	Data from the coin selector
Master – Slave assignment <sup>1)</sup>	7Fh	23h	8 Bytes Z1 to Z8

Z1 – Z8 Master – Slave assignment, coded in one nibble. Beginning with the master for channel 17 (slave 1) in the upper nibble of Z1 to the master for channel 32 (slave 16) in the bottom nibble of Z8.

<sup>1)</sup> This command is available on all coin selectors with microprocessor version wh789v3 (January 2001) onwards

Command	Code	Data from the Coin Selector
POLL	7Bh	1 byte

When a response is given it is important whether the coin selector is operating in ordinary or in extended MDB protocol.

- ordinary multi drop bus protocol

00h	no result (ACK)
07h	reset
8nh	type n <sup>1)</sup>
90h	coin return button pressed
91h	subsequent coin in measuring system
92h	coin jamming 1
93h	coin does not match parameter set
94h	multi drop blocking
95h	coin jamming 2
96h	coin blocking
97h	coin jamming 3
98h	coin jamming 4
99h	coin jamming 5
9Ah	rim detection error
9Bh	lead detection
9Ch	coin following too closely in TCAP1
9Dh	coin-on-a-thread detection
9Eh	sorting error
9Fh	coin selector busy

1)

If “Report 32 channel” has been activated (“Configuration”, “B-values” and “Receipt” tab) the channels 1 to 16 are reported with 80h to 8Fh and channels 17 to 32 are reported with 70h to 7Fh. This is a special wh Münzprüfer function, as the MDB specifications only define for a maximum of 16 coin channels.

- Extended Multi Drop Bus Protocol

00h		No result (ACK)	
07h		Reset	
8nh	0nh	type n <sup>1)</sup>	shaft m
90h	8nh	coin return button pressed	type n <sup>1)</sup>
91h	8nh	subsequent coin in measuring system	type n <sup>1)</sup>
92h		coin jamming 1	
93h		coin does not match parameter set	
94h	8nh	multi drop blocking	type n <sup>1)</sup>
95h	8nh	coin jamming 2	type n <sup>1)</sup>
96h	8nh	coin blocking	type n <sup>1)</sup>
97h	8nh	coin jamming 3	type n <sup>1)</sup>
98h	8nh	coin jamming 4	type n <sup>1)</sup>
99h	8nh	coin jamming 5	type n <sup>1)</sup>
9Ah		rim detection error	
9Bh		lead detection	
9Ch	8nh	coin following to closely in TCAP1	type n <sup>1)</sup>
9Dh	8nh	coin-on-a-thread detection	type n <sup>1)</sup>
9Eh	8nh	sorting error	type n <sup>1)</sup>
9Fh		coin selector busy	

1)

If “Report 32 channel” has been activated (“Configuration”, “B-values” and “Receipt” tab) the channels 1 to 16 are reported with 80h to 8Fh and channels 17 to 32 are reported with 70h to 7Fh. This is a special wh Münzprüfer function, as the MDB specifications only define for a maximum of 16 coin channels.

<b>Command</b>	<b>Code</b>	<b>Data to the Coin Selector</b>
Coin Type	7Ch	4 Bytes Y1 to Y4

Y1 - Y2	coin release for each type 1 bit, 1 = release Note: the least significant bit is assigned to type 1!
Y3 - Y4	coin in main cash box for each type 1 bit, 1 = to main cash Note: the least significant bit is assigned to type 1!

The coin type command is equally valid for the master and all assigned slave units.

<b>Command</b>	<b>Code</b>	<b>Modifier</b>	<b>Data to the Coin Selector</b>
Extended Coin Type	7Fh	20h	6 Bytes Y1 to Y6

Y1 – Y4	coin release for each type 1 bit, 1 = release Note: the least significant bit is assigned to type 1!
Y5 – Y6	coin in main cash box for each type 1 bit, 1 = to main cash Note: the least significant bit is assigned to type 1!

The extended coin type command allows for the individual blocking or unblocking of each of the 32 coin channels. The main coin box rerouting applies to all master and associated slave channels equally.



<u>Command</u>	<u>Code</u>	<u>Data to the Coin Selector</u>
Channel assignment	7Eh	9 Bytes Y1 to Y9
Y1	Number of the main coin box	
Y2 – Y9	Assignment of the channel/shaft, one nibble each	
Y2 Y3	Channel 1/2 2/3	



The given default coin sorting sequence is reverted to after a reset.

<u>Command</u>	<u>Code</u>	<u>Modifier</u>	<u>Data from the Coin Selector</u>
Identify	7Fh	00h	33 Bytes Z1 to Z33
Z0 - Z3	WHM		
Z4 - Z15	number of machine		
Z16- Z27	number of model / bar code		
Z28- Z29	software version packed BCD-code		
Z30- Z33	future options		

<u>Command</u>	<u>Code</u>	<u>Modifier</u>	<u>Data from the Coin Selector</u>
Request	7Fh	01h	13 Bytes Z1 to Z13
Z1 – Z2	Coin Release, 1 Bit per type, 1 = Unblock coin		
Z3 – Z4	Coin routed to main coin box, 1 Bit per type, 1 = Main coin box		
Z5	Main coin box sorting shaft		
Z6 – Z13	Sorting shaft number of each type of coin; one nibble per type, beginning with type 1 in the upper nibble Z6		

This request is used to establish the actual blocking and sorting of the 16 master channels.

<u>Command</u>	<u>Code</u>	<u>Modifier</u>	<u>Data from the Coin Selector</u>
Extended Request	7Fh	21h	15 Bytes Z1 to Z15
Z1 – Z4	Coin Release, 1 Bit per type, 1 = Unblock coin		
Z5 – Z6	Coin routed to main coin box, 1 Bit per type, 1 = Main coin box		
Z7	Main coin box sorting shaft		
Z8 – Z15	Sorting shaft number of each type of coin; one nibble per type, beginning with type 1 in the upper nibble Z8		

The extended request is used to establish the actual coin release and sorting of all 32 channels. The sorting of the master and slave channels are always the same.

### 3.3.4 Multi Drop Bus and Battery Operation

With the EMP 800 v5 it is now possible for the coin selector to be battery operated, even when using the MDB protocol.

Various improvements and changes were made in order to make it easier to implement this protocol in a battery operated vending environment.

#### 3.3.4.1 Coin Type Default

Prior to the new v5, it has proved difficult for the machine controller to initialize the coin selector once it has turned itself on because it has detected a coin. That is, it was difficult to send the coin type command in time so that the inserted coin could still be accepted.

In order to make things easier, the coin selector now has the facility to initialize itself when in MDB mode. In *wheasy 3*, select „Configuration“, then „B-values“, and select the „Mode“ tab. Check “Coin type default”. The coin selector will initialize the Coin type command from its own EEPROM after power up and therefore is immediately ready to accept coins. In this mode no “Reset” message is sent after

the power on Reset, because this information must be transferred first after the poll command. There may not be enough time to do this if the coin selector has to be instantly ready to accept coins.

A coin type command, which is sent from the machine controller to the coin selector is stored in the EEPROM in this mode and therefore still valid after a power on reset until the next coin type command is received.

### **3.3.4.2 Polling**

The coin selector only turns itself off after accepting a coin and after the information has been retrieved by the polling machine controller. However, the coin selector will turn itself off after two seconds if this polling does not happen.

A special procedure must be followed to send a coin type command to a battery operated coin selector. The coin type command must be sent after switching the device on and before a polling command, because otherwise the coin selector will turn itself off first.

As an alternative, the polling can be sent, but without responding to the ACK sent by the coin selector. The coin selector will also not turn off in this case, and so the coin type command can still be received. In this case the polling can be sent again, and the coin selector will respond as it did the previous time. This second polling must then be responded to with the ACK, at which point the coin selector will turn itself off.

### 3.4 cctalk interface

A 4-pin JST connector B 4B-XH-A is used for the cctalk interface

PIN Nr.	Connection
1	UB (10 ... 16 Vdc)
2	Not used
3	GND
4	Data Line (Bi-directional)

Coin selector selectors to be used with cctalk interface have to be set to MDB. The coin selectors recognises automatically the active protocol of the connected controller.

#### 3.4.1 Command overview

Header	Function	Answer, data and remarks
254	Simple poll	Answer with ACK
253	Address poll	MDCES support acc. to specification
252	Address clash	MDCES support acc. to specification
251	Address change	MDCES support acc. to specification
250	Address random	MDCES support acc. to specification
249	Request polling priority	[002][020] = 10ms x 20 = 200ms
288	Request status	[000] = OK [001] = reject confirmed [002] = coin on a string manipulation
247	Request variable set	2 Byte customer identification (wh specific)
246	Request manufacturer id	,wh Berlin'
245	Request equipment category id	,Coin Acceptor'
244	Request product code	,EMP'
243	Request database version	[000] = no remote programming via cctalk
242	Request serial number	[032][003][000]
241	Request software revision	,EMP-V4.29b' or later version
240	Test solenoids	Bit 0 = acceptance solenoid Bit 1 = solenoid 1 Bit 2 = solenoid 2 Bit 3 = solenoid 3 activated for 500ms
238	Test output lines	Bit 0...7 = output 1...8 activated for 500ms
237	Read input lines	2 Byte Status DIP-Switch 1 and 2

236	Read opto states	Bit 0 = acceptance light barrier Bit 1 = reject light barrier
233	Latch output lines	Bit 0...7 = output 1...8 activated continuously
232	Perform self-check	Answer with ACK, no activities
231	Modify inhibit status	2 Bytes for 16 coins 0 = blocked, 1 = released, all blocked after power on
230	Request inhibit status	[inhibit 1][inhibit 2]
229	Read buffered credit or error codes	Buffer with 5 events, see also table 2 must be transmitted at least every 500 ms, otherwise the coin acceptance will be blocked.
227	Request master inhibit status	[inhibit] Bit 0 gives general blocking: 0 = blocked, 1 = released
226	Request insertion counter	[count1][count2][count3] Number of inserts since power on
225	Request accept counter	[count1][count2][count3] Number of accepted coins since power on
222	Modify sorter override status	2 Byte for 16 coins main cash box redirection, 0 = into main cash box, 1 = normal routing, After Power on normal routing for all coins is activated
221	Request sorter override status	[override1][override2] Polling of main cash box redirecting
216	Request data storage availability	[000] [000] [000] [000] [000] no more data storage available
213	Request option flags	[000] „Coin Position Format“ is used
212	Request coin position	[pos1][pos2] provides inhibit vector for given coin number
210	Modify sorter path	Changes sorting path for given coin number. After power on the preset shaft is active.
209	Request sorter path	Provides sorting path for given coin number
202	Teach mode control	Answer with ACK, not supported
201	Request teach status	Answer with ACK, not supported
197	Calculate ROM checksum	[000] [000] [000] [000], no activities
196	Request creation date	Provides date of last factory programming
195	Request last modification date	Provides date of last customer programming
194	Request reject counter	[count1][count2][count3] number of rejects since power-on

193	Request fraud counter	[000] [000] [000], not supported
192	Request build code	Provides 16 ASCII codes technical specification
185	Modify coin id	Actually not supported, changes are only possible using wheasy 3 from version 3.08 onwards
184	Request coin id	Provides 6 ASCII codes coin ID, for example EU200A
183	Upload window data	Answer with ACK, not supported
182	Download calibration info	Answer with ACK, not supported
173	Request thermistor reading	Answer with ACK, not supported
170	Request base year	,2000'
169	Request address mode	[132] Address is stored in EEPROM and can be changed
4	Request comms revision	[001][004][000] cctalk level 1, Specification 4.0
3	Clear comm status variables	Clears communication error counters
2	Request comm status variables	Provides 3 communication error counters
1	Reset device	Carries out Software Reset

### 3.4.2 Assigning MDB error codes to cctalk error codes

MDB	Remark	cctalk	Remark
\$90	Coin return button pressed	254	Coin return button pressed
\$91	Subsequent coin	8	Subsequent coin
\$92	Coin jamming 1	19	Coin too slow
\$93	Coin does not match parameter set	1	Coin rejected
\$94	MDB blocking	2	Coin blocked
\$95	Coin jamming 2	19	Coin too slow
\$96	DIP switch blocking	2	Coin blocked
\$97	Coin jamming 3	19	Coin too slow
\$98	Coin jamming 4	19	Coin too slow
\$99	Coin jamming 6	19	Coin too slow
\$9A	Rim detection error	1	Coin rejected
\$9B	Lead detection	1	Coin rejected
\$9C	Old: coin following to closely in TCAP1	255	Unknown error
\$9D	Coin on a thread detection	20	Coin on a thread manipulation

\$9E	General blocking	2	Coin blocked
\$9F	EMP busy	13	Not ready

### 3.4.3 cctalk adjustments using wheasy 3

Using *wheasy 3* all cctalk settings can be carried out under “configuration” – “cctalk”.

Figure 13 shows the window with the cctalk adjustments. Coin ID according to cctalk specifications as well as initial address of coin selector can be set here. For most currencies these IDs can be taken out of the indications given under “Coin value” and “status and identify” (generate switch)

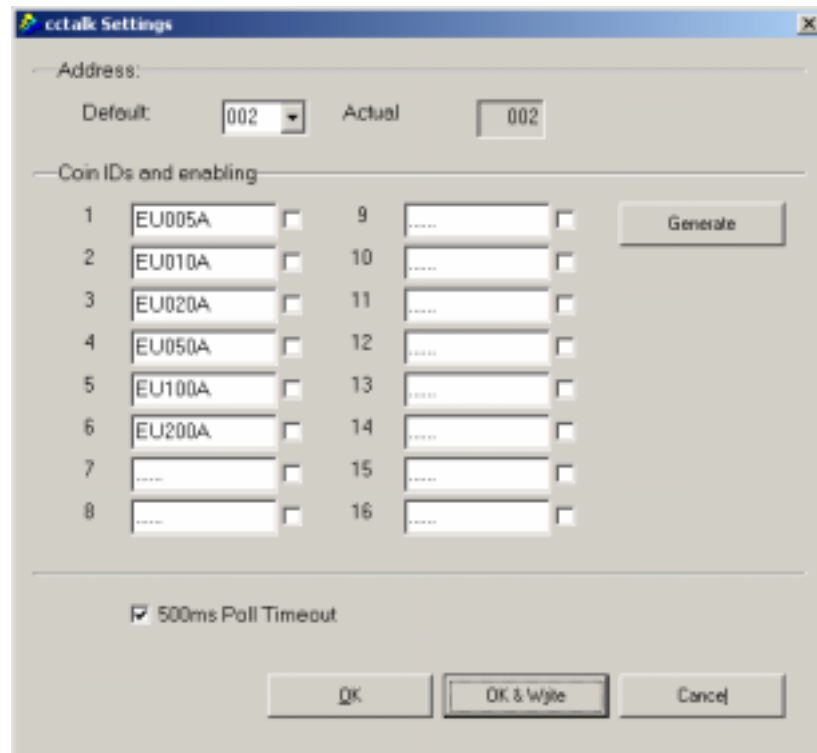

Figure 13 cctalk settings

In some special cases it is necessary to have a configuration that differs from the specifications. For example all coins should be released during power on and “500 ms Poll Timeout” should be deactivated in case the coin selector is supposed to be used with cctalk and parallel interface at the same time.

## 4 The Label

The label of the coin selector has all the necessary information required by the machine controller such as the output lines and blocking switch configurations. The following section explains and clarifies the format and legend on the label.

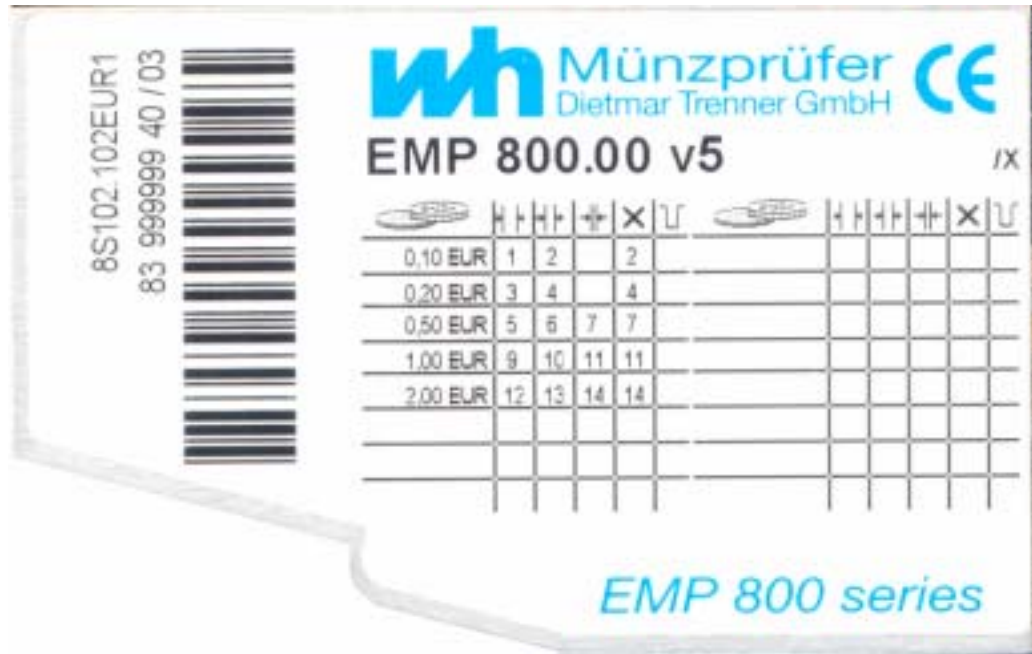

Figure 14 Example of an EMP 800 v5 Label

At the top is printed the exact type of coin selector. In this example:

EMP 800.00 v5

At the end of the same line you find the installed options. In this example:

/X Control for external sorting flaps

On the left, besides the barcode (turned 90°) is the serial number and the week and year of manufacture. The same information is contained in the bar code. On the very left is the number of the technical specification, that has been used when programming the device in the factory.

The remaining space on the label is devoted to the specification of the programmed coins. These specifications are in the form of a table. The columns have the following meaning:



Coin type (Value and currency)

Teach mode channels are marked with TKn. „n“ = number of blocking switch, which has to be used to activate the teach mode for this channel



Blocking switch for the broad channel



Blocking switch for the narrow channel



Blocking switch for the very narrow channel



Blocking switch for a coin type or coin group (currency)



Output line

The output line is specified directly for the EMP 8x0.00 v5, which is a number between 1 and 6. The output line combination is given in the hexadecimal equivalent for binary code in the EMP 8xx.04 v5.

## **5 Maintenance**

The EMP 800 v5 is an extraordinarily robust coin selector and operates relatively maintenance free. However, it should be cleaned at regular intervals especially if it is operating in an environment with high levels of dust, smoke or nicotine. The cleaning intervals are of course dependent on the level of air borne contaminants.

Modest use with minimum contaminant levels indicate the need to clean the top of the coin path once a year. Open the coin path door and wipe the exposed surfaces with an alcohol moistened cloth. The light sensors may be cleaned with a soft brush or air spray duster.



## 6 Connecting Diagrams

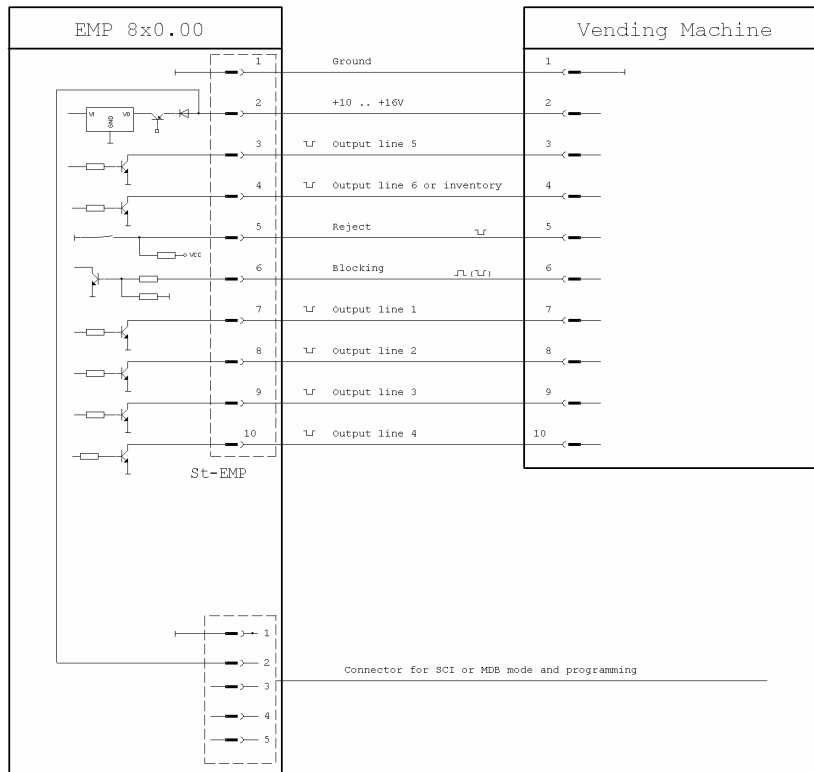

Figure 15 Connecting diagram EMP 8x0.00 v5

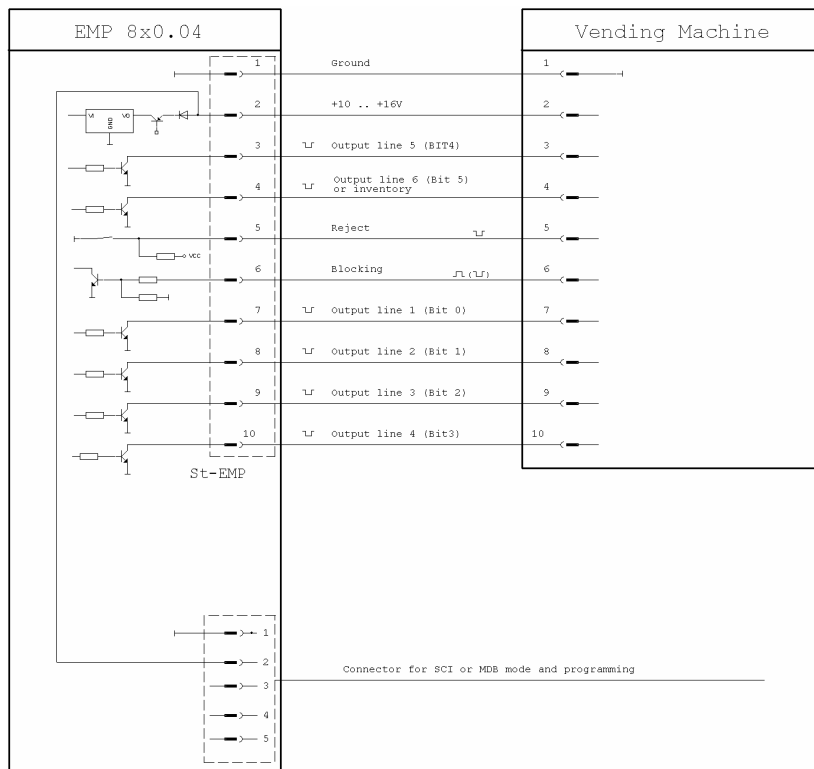

Figure 16 Connecting diagram EMP 8x0.04 v5

## 7 EG Conformation Declaration

Product name: EMP 8x0.00 v5, EMP 8x0.04 v5 and EMP 8x0.13 v5  
Date: 10/03

### **Harmonized European Standard:**

EN 50081-1  
EN 55014-2  
EN50082-1 (Criterion B for Level 2, Criterion C1 for Level 3)

### **IEC-Standard**

IEC 801-4 (Criterion B for Level 2, Criterion C1 for Level 3)

The EC Standard Specifications which are still in the process of being developed have applied up to now for finished products and their bringing into circulation. Tests are effected according to the EMC regulations, which means certification of electromagnetic compatibility and, if applicable, of interference (emission). The tests have been realized according to EN 50082-1 and EN 50081-1. These tests grant, that electronic coin selectors of type EMP 8x0.00 v5, EMP 8x0.04 v5 and EMP 8x0.13 v5 meet general regulations. However, they do not exempt the seller of the machines from his duty of care as there are still some other important characteristics of the machine which could impede the EM conformity or restrict it.